



COMMONWEALTH OF PENNSYLVANIA
DEPARTMENT OF ENVIRONMENTAL PROTECTION
AIR QUALITY PROGRAM

TITLE V/STATE OPERATING PERMIT

Issue Date: July 31, 2023

Effective Date: July 31, 2023

Expiration Date: July 30, 2028

In accordance with the provisions of the Air Pollution Control Act, the Act of January 8, 1960, P.L. 2119, as amended, and 25 Pa. Code Chapter 127, the Owner, [and Operator if noted] (hereinafter referred to as permittee) identified below is authorized by the Department of Environmental Protection (Department) to operate the air emission source(s) more fully described in this permit. This Facility is subject to all terms and conditions specified in this permit. Nothing in this permit relieves the permittee from its obligations to comply with all applicable Federal, State and Local laws and regulations.

The regulatory or statutory authority for each permit condition is set forth in brackets. All terms and conditions in this permit are federally enforceable applicable requirements unless otherwise designated as "State-Only" or "non-applicable" requirements.

TITLE V Permit No: 49-00007

Federal Tax Id - Plant Code: 27-3274092-1

Owner Information

Name: CHEROKEE PHARM LLC
Mailing Address: 100 AVE C
RIVERSIDE, PA 17868

Plant Information

Plant: CHEROKEE PHARM LLC/RIVERSIDE BORO PLT
Location: 49 Northumberland County 49924 Riverside Borough
SIC Code: 2833 Manufacturing - Medicinals And Botanicals

Responsible Official

Name: RONALD RESELE
Title: PLANT MGR
Phone: (570) 271 - 2001 Email: Ronald.Resele@merck.com

Permit Contact Person

Name: DANIEL MORRIS
Title: DIR - SAFETY & ENV
Phone: (570) 271 - 2187 Email: daniel.morris@merck.com

[Signature] _____
MUHAMMAD Q. ZAMAN, ENVIRONMENTAL PROGRAM MANAGER, NORTHCENTRAL REGION



SECTION A. Table of Contents

Section A. Facility/Source Identification

Table of Contents
Site Inventory List

Section B. General Title V Requirements

- #001 Definitions
- #002 Prohibition of Air Pollution
- #003 Property Rights
- #004 Permit Expiration
- #005 Permit Renewal
- #006 Transfer of Ownership or Operational Control
- #007 Inspection and Entry
- #008 Compliance Requirements
- #009 Need to Halt or Reduce Activity Not a Defense
- #010 Duty to Provide Information
- #011 Reopening and Revising the Title V Permit for Cause
- #012 Reopening a Title V Permit for Cause by EPA
- #013 Operating Permit Application Review by the EPA
- #014 Significant Operating Permit Modifications
- #015 Minor Operating Permit Modifications
- #016 Administrative Operating Permit Amendments
- #017 Severability Clause
- #018 Fee Payment
- #019 Authorization for De Minimis Emission Increases
- #020 Reactivation of Sources
- #021 Circumvention
- #022 Submissions
- #023 Sampling, Testing and Monitoring Procedures
- #024 Recordkeeping Requirements
- #025 Reporting Requirements
- #026 Compliance Certification
- #027 Operational Flexibility
- #028 Risk Management
- #029 Approved Economic Incentives and Emission Trading Programs
- #030 Permit Shield
- #031 Reporting
- #032 Report Format

Section C. Site Level Title V Requirements

- C-I: Restrictions
- C-II: Testing Requirements
- C-III: Monitoring Requirements
- C-IV: Recordkeeping Requirements
- C-V: Reporting Requirements
- C-VI: Work Practice Standards
- C-VII: Additional Requirements
- C-VIII: Compliance Certification
- C-IX: Compliance Schedule

Section D. Source Level Title V Requirements

- D-I: Restrictions
- D-II: Testing Requirements
- D-III: Monitoring Requirements
- D-IV: Recordkeeping Requirements
- D-V: Reporting Requirements



SECTION A. Table of Contents

D-VI: Work Practice Standards
D-VII: Additional Requirements

Note: These same sub-sections are repeated for each source!

Section E. Source Group Restrictions

E-I: Restrictions
E-II: Testing Requirements
E-III: Monitoring Requirements
E-IV: Recordkeeping Requirements
E-V: Reporting Requirements
E-VI: Work Practice Standards
E-VII: Additional Requirements

Section F. Alternative Operating Scenario(s)

F-I: Restrictions
F-II: Testing Requirements
F-III: Monitoring Requirements
F-IV: Recordkeeping Requirements
F-V: Reporting Requirements
F-VI: Work Practice Standards
F-VII: Additional Requirements

Section G. Emission Restriction Summary

Section H. Miscellaneous

**SECTION A. Site Inventory List**

Source ID	Source Name	Capacity/Throughput	Fuel/Material
036	BOILER SG-B		
037	BOILER SG-C		
101	WASTEWATER TREATMENT PLANT		
102	SLUDGE DRYING OPERATIONS		
131	300 PAD WASTEWATER SYSTEM		
135	ERC AWARDED SOURCES		
140	PHARMACEUTICAL/CHEMICAL MANUFACTURING		
145	THERMAL OXIDIZERS AND SCRUBBER UNITS		
155	BULK STORAGE TANKS		
162	FUEL STORAGE TANKS		
165	GLYCOL TANKS		
175	RECIPROCATING INTERNAL COMBUSTION ENGINES		
180	LOADING OPERATIONS		
250	DRUM HANDLING AND SAMPLING AREA		
260	ONSITE LABORATORIES		
C132	PHARM/CHEMICAL CAMPAIGN ABSOLUTE FILTERS		
C152	PHARM/CHEMICAL CAMPGN SCRUBBERS		
C153	PACKED BED SCRUBBER CL-3520		
C155	PACKED BED SCRUBBER CL-1673		
C500	LPV14M THERMAL OXIDIZER (IN-2050)		
C501	CEILCOTE SPT54120 P.B. SCRUBBER		
C502	VENTURI/PACKED BED SCRUBBER (CL-1053)		
FM004	NATURAL GAS LINE		
FM005	#2 OIL TANK TA-5000		
FM006	#2 OIL STORAGE TANKS		
FM007	PROPANE TANKS		
S036	BOILER SG-B STACK		
S037	BOILER SG-C STACK		
S153	SCRUBBER CL-3520 STACK		
S155	SCRUBBER CL-1673 STACK		
S159	PHARM/CHEMICAL SCRUBBER STACKS		
S175	GEN/COMP/PUMP STACKS		
S260	FUME HOOD STACKS		
S501	SCRUBBER STACK		
V102	SLUDGE DRYER PROC VENTS		
V130	PHARM/CHEMICAL CAMPAIGN PROCESS VENTS		
Z101	WWTP FUGITIVES		
Z131	300 PAD SYSTEM FUG EMISS		
Z160	BULK TANK FUGITIVES		
Z162	#2 OIL TANK FUGITIVES		

**SECTION A. Site Inventory List**

Source ID	Source Name	Capacity/Throughput	Fuel/Material
Z165	GLYCOL TANKS FUGITIVES		
Z180	FUGITIVE EMISS		
Z250	DRUM HANDLING & SAMPLING FUGITIVES		

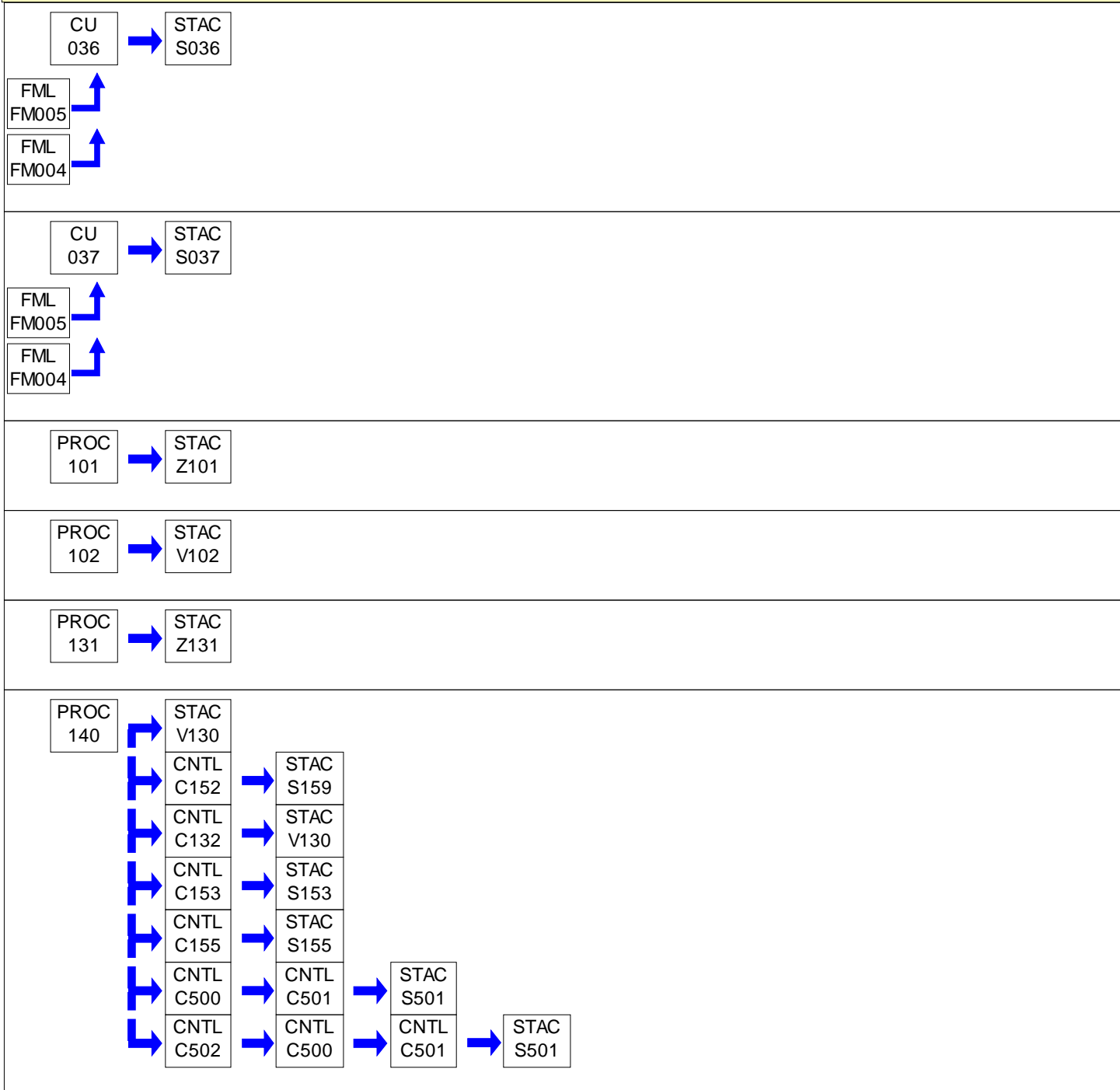
PERMIT MAPS



PERMIT MAPS

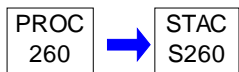
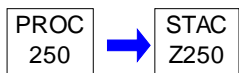
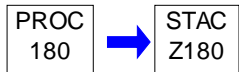
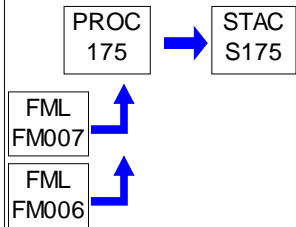
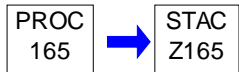
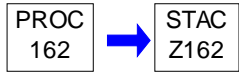
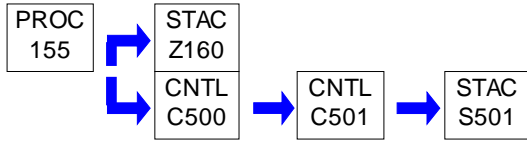
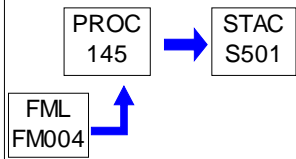

**SECTION B. General Title V Requirements****#001 [25 Pa. Code § 121.1]****Definitions**

Words and terms that are not otherwise defined in this permit shall have the meanings set forth in Section 3 of the Air Pollution Control Act (35 P.S. § 4003) and 25 Pa. Code § 121.1.

#002 [25 Pa. Code § 121.7]**Prohibition of Air Pollution**

No person may permit air pollution as that term is defined in the act.

#003 [25 Pa. Code § 127.512(c)(4)]**Property Rights**

This permit does not convey property rights of any sort, or any exclusive privileges.

#004 [25 Pa. Code § 127.446(a) and (c)]**Permit Expiration**

This operating permit is issued for a fixed term of five (5) years and shall expire on the date specified on Page 1 of this permit. The terms and conditions of the expired permit shall automatically continue pending issuance of a new Title V permit, provided the permittee has submitted a timely and complete application and paid applicable fees required under 25 Pa. Code Chapter 127, Subchapter I and the Department is unable, through no fault of the permittee, to issue or deny a new permit before the expiration of the previous permit. An application is complete if it contains sufficient information to begin processing the application, has the applicable sections completed and has been signed by a responsible official.

#005 [25 Pa. Code §§ 127.412, 127.413, 127.414, 127.446(e), 127.503 & 127.704(b)]**Permit Renewal**

(a) An application for the renewal of the Title V permit shall be submitted to the Department at least six (6) months, and not more than 18 months, before the expiration date of this permit. The renewal application is timely if a complete application is submitted to the Department's Regional Air Manager within the timeframe specified in this permit condition.

(b) The application for permit renewal shall include the current permit number, the appropriate permit renewal fee, a description of any permit revisions and off-permit changes that occurred during the permit term, and any applicable requirements that were promulgated and not incorporated into the permit during the permit term. The fees shall be made payable to "The Commonwealth of Pennsylvania Clean Air Fund" and submitted with the fee form to the respective regional office.

(c) The renewal application shall also include submission of proof that the local municipality and county, in which the facility is located, have been notified in accordance with 25 Pa. Code § 127.413. The application for renewal of the Title V permit shall also include submission of compliance review forms which have been used by the permittee to update information submitted in accordance with either 25 Pa. Code § 127.412(b) or § 127.412(j).

(d) The permittee, upon becoming aware that any relevant facts were omitted or incorrect information was submitted in the permit application, shall promptly submit such supplementary facts or corrected information during the permit renewal process. The permittee shall also promptly provide additional information as necessary to address any requirements that become applicable to the source after the date a complete renewal application was submitted but prior to release of a draft permit.

#006 [25 Pa. Code §§ 127.450(a)(4) & 127.464(a)]**Transfer of Ownership or Operational Control**

(a) In accordance with 25 Pa. Code § 127.450(a)(4), a change in ownership or operational control of the source shall be treated as an administrative amendment if:

(1) The Department determines that no other change in the permit is necessary;

(2) A written agreement has been submitted to the Department identifying the specific date of the transfer of permit responsibility, coverage and liability between the current and the new permittee; and,

(3) A compliance review form has been submitted to the Department and the permit transfer has been approved by

**SECTION B. General Title V Requirements**

the Department.

(b) In accordance with 25 Pa. Code § 127.464(a), this permit may not be transferred to another person except in cases of transfer-of-ownership which are documented and approved to the satisfaction of the Department.

#007 [25 Pa. Code § 127.513, 35 P.S. § 4008 and § 114 of the CAA]**Inspection and Entry**

(a) Upon presentation of credentials and other documents as may be required by law for inspection and entry purposes, the permittee shall allow the Department of Environmental Protection or authorized representatives of the Department to perform the following:

- (1) Enter at reasonable times upon the permittee's premises where a Title V source is located or emissions related activity is conducted, or where records are kept under the conditions of this permit;
- (2) Have access to and copy or remove, at reasonable times, records that are kept under the conditions of this permit;
- (3) Inspect at reasonable times, facilities, equipment including monitoring and air pollution control equipment, practices, or operations regulated or required under this permit;
- (4) Sample or monitor, at reasonable times, substances or parameters, for the purpose of assuring compliance with the permit or applicable requirements as authorized by the Clean Air Act, the Air Pollution Control Act, or the regulations promulgated under the Acts.

(b) Pursuant to 35 P.S. § 4008, no person shall hinder, obstruct, prevent or interfere with the Department or its personnel in the performance of any duty authorized under the Air Pollution Control Act.

(c) Nothing in this permit condition shall limit the ability of the EPA to inspect or enter the premises of the permittee in accordance with Section 114 or other applicable provisions of the Clean Air Act.

#008 [25 Pa. Code §§ 127.25, 127.444, & 127.512(c)(1)]**Compliance Requirements**

(a) The permittee shall comply with the conditions of this permit. Noncompliance with this permit constitutes a violation of the Clean Air Act and the Air Pollution Control Act and is grounds for one (1) or more of the following:

- (1) Enforcement action
- (2) Permit termination, revocation and reissuance or modification
- (3) Denial of a permit renewal application

(b) A person may not cause or permit the operation of a source, which is subject to 25 Pa. Code Article III, unless the source(s) and air cleaning devices identified in the application for the plan approval and operating permit and the plan approval issued to the source are operated and maintained in accordance with specifications in the applications and the conditions in the plan approval and operating permit issued by the Department. A person may not cause or permit the operation of an air contamination source subject to 25 Pa. Code Chapter 127 in a manner inconsistent with good operating practices.

(c) For purposes of Sub-condition (b) of this permit condition, the specifications in applications for plan approvals and operating permits are the physical configurations and engineering design details which the Department determines are essential for the permittee's compliance with the applicable requirements in this Title V permit.

#009 [25 Pa. Code § 127.512(c)(2)]**Need to Halt or Reduce Activity Not a Defense**

It shall not be a defense for a permittee in an enforcement action that it would have been necessary to halt or reduce the permitted activity in order to maintain compliance with the conditions of this permit.

**SECTION B. General Title V Requirements****#010 [25 Pa. Code §§ 127.411(d) & 127.512(c)(5)]****Duty to Provide Information**

(a) The permittee shall furnish to the Department, within a reasonable time, information that the Department may request in writing to determine whether cause exists for modifying, revoking and reissuing, or terminating the permit, or to determine compliance with the permit.

(b) Upon request, the permittee shall also furnish to the Department copies of records that the permittee is required to keep by this permit, or for information claimed to be confidential, the permittee may furnish such records directly to the Administrator of EPA along with a claim of confidentiality.

#011 [25 Pa. Code §§ 127.463, 127.512(c)(3) & 127.542]**Reopening and Revising the Title V Permit for Cause**

(a) This Title V permit may be modified, revoked, reopened and reissued or terminated for cause. The filing of a request by the permittee for a permit modification, revocation and reissuance, or termination, or of a notification of planned changes or anticipated noncompliance does not stay a permit condition.

(b) This permit may be reopened, revised and reissued prior to expiration of the permit under one or more of the following circumstances:

(1) Additional applicable requirements under the Clean Air Act or the Air Pollution Control Act become applicable to a Title V facility with a remaining permit term of three (3) or more years prior to the expiration date of this permit. The Department will revise the permit as expeditiously as practicable but not later than 18 months after promulgation of the applicable standards or regulations. No such revision is required if the effective date of the requirement is later than the expiration date of this permit, unless the original permit or its terms and conditions has been extended.

(2) Additional requirements, including excess emissions requirements, become applicable to an affected source under the acid rain program. Upon approval by the Administrator of EPA, excess emissions offset plans for an affected source shall be incorporated into the permit.

(3) The Department or the EPA determines that this permit contains a material mistake or inaccurate statements were made in establishing the emissions standards or other terms or conditions of this permit.

(4) The Department or the Administrator of EPA determines that the permit must be revised or revoked to assure compliance with the applicable requirements.

(c) Proceedings to revise this permit shall follow the same procedures which apply to initial permit issuance and shall affect only those parts of this permit for which cause to revise exists. The revision shall be made as expeditiously as practicable.

(d) Regardless of whether a revision is made in accordance with (b)(1) above, the permittee shall meet the applicable standards or regulations promulgated under the Clean Air Act within the time frame required by standards or regulations.

#012 [25 Pa. Code § 127.543]**Reopening a Title V Permit for Cause by EPA**

As required by the Clean Air Act and regulations adopted thereunder, this permit may be modified, reopened and reissued, revoked or terminated for cause by EPA in accordance with procedures specified in 25 Pa. Code § 127.543.

#013 [25 Pa. Code § 127.522(a)]**Operating Permit Application Review by the EPA**

The applicant may be required by the Department to provide a copy of the permit application, including the compliance plan, directly to the Administrator of the EPA. Copies of title V permit applications to EPA, pursuant to 25 PA Code §127.522(a), shall be submitted, if required, to the following EPA e-mail box:

R3_Air_Apps_and_Notices@epa.gov

Please place the following in the subject line: TV [permit number], [Facility Name].

**SECTION B. General Title V Requirements****#014 [25 Pa. Code § 127.541]****Significant Operating Permit Modifications**

When permit modifications during the term of this permit do not qualify as minor permit modifications or administrative amendments, the permittee shall submit an application for significant Title V permit modifications in accordance with 25 Pa. Code § 127.541. Notifications to EPA, pursuant to 25 PA Code §127.522(a), if required, shall be submitted, to the following EPA e-mail box:

R3_Air_Apps_and_Notices@epa.gov

Please place the following in the subject line: TV [permit number], [Facility Name].

#015 [25 Pa. Code §§ 121.1 & 127.462]**Minor Operating Permit Modifications**

The permittee may make minor operating permit modifications (as defined in 25 Pa. Code §121.1), on an expedited basis, in accordance with 25 Pa. Code §127.462 (relating to minor operating permit modifications). Notifications to EPA, pursuant to 25 PA Code §127.462(c), if required, shall be submitted, to the following EPA e-mail box:

R3_Air_Apps_and_Notices@epa.gov

Please place the following in the subject line: TV [permit number], [Facility Name].

#016 [25 Pa. Code § 127.450]**Administrative Operating Permit Amendments**

(a) The permittee may request administrative operating permit amendments, as defined in 25 Pa. Code §127.450(a). Copies of request for administrative permit amendment to EPA, pursuant to 25 PA Code §127.450(c)(1), if required, shall be submitted to the following EPA e-mail box:

R3_Air_Apps_and_Notices@epa.gov

Please place the following in the subject line: TV [permit number], [Facility Name].

(b) Upon final action by the Department granting a request for an administrative operating permit amendment covered under §127.450(a)(5), the permit shield provisions in 25 Pa. Code § 127.516 (relating to permit shield) shall apply to administrative permit amendments incorporated in this Title V Permit in accordance with §127.450(c), unless precluded by the Clean Air Act or the regulations thereunder.

#017 [25 Pa. Code § 127.512(b)]**Severability Clause**

The provisions of this permit are severable, and if any provision of this permit is determined by the Environmental Hearing Board or a court of competent jurisdiction, or US EPA to be invalid or unenforceable, such a determination will not affect the remaining provisions of this permit.

#018 [25 Pa. Code §§ 127.704, 127.705 & 127.707]**Fee Payment**

(a) The permittee shall pay fees to the Department in accordance with the applicable fee schedules in 25 Pa. Code Chapter 127, Subchapter I (relating to plan approval and operating permit fees). The applicable fees shall be made payable to "The Commonwealth of Pennsylvania Clean Air Fund" with the permit number clearly indicated and submitted to the respective regional office.

(b) Emission Fees. The permittee shall, on or before September 1st of each year, pay applicable annual Title V emission fees for emissions occurring in the previous calendar year as specified in 25 Pa. Code § 127.705. The permittee is not required to pay an emission fee for emissions of more than 4,000 tons of each regulated pollutant emitted from the facility.

(c) As used in this permit condition, the term "regulated pollutant" is defined as a VOC, each pollutant regulated under Sections 111 and 112 of the Clean Air Act and each pollutant for which a National Ambient Air Quality Standard has been promulgated, except that carbon monoxide is excluded.

**SECTION B. General Title V Requirements**

(d) Late Payment. Late payment of emission fees will subject the permittee to the penalties prescribed in 25 Pa. Code § 127.707 and may result in the suspension or termination of the Title V permit. The permittee shall pay a penalty of fifty percent (50%) of the fee amount, plus interest on the fee amount computed in accordance with 26 U.S.C.A. § 6621(a)(2) from the date the emission fee should have been paid in accordance with the time frame specified in 25 Pa. Code § 127.705(c).

(e) The permittee shall pay an annual operating permit maintenance fee according to the following fee schedule established in 25 Pa. Code § 127.704(d) on or before December 31 of each year for the next calendar year.

(1) Eight thousand dollars (\$8,000) for calendar years 2021—2025.

(2) Ten thousand dollars (\$10,000) for calendar years 2026—2030.

(3) Twelve thousand five hundred dollars (\$12,500) for the calendar years beginning with 2031.

#019 [25 Pa. Code §§ 127.14(b) & 127.449]**Authorization for De Minimis Emission Increases**

(a) This permit authorizes de minimis emission increases from a new or existing source in accordance with 25 Pa. Code §§ 127.14 and 127.449 without the need for a plan approval or prior issuance of a permit modification. The permittee shall provide the Department with seven (7) days prior written notice before commencing any de minimis emissions increase that would result from either: (1) a physical change of minor significance under § 127.14(c)(1); or (2) the construction, installation, modification or reactivation of an air contamination source. The written notice shall:

(1) Identify and describe the pollutants that will be emitted as a result of the de minimis emissions increase.

(2) Provide emission rates expressed in tons per year and in terms necessary to establish compliance consistent with any applicable requirement.

The Department may disapprove or condition de minimis emission increases at any time.

(b) Except as provided below in (c) and (d) of this permit condition, the permittee is authorized during the term of this permit to make de minimis emission increases (expressed in tons per year) up to the following amounts without the need for a plan approval or prior issuance of a permit modification:

(1) Four tons of carbon monoxide from a single source during the term of the permit and 20 tons of carbon monoxide at the facility during the term of the permit.

(2) One ton of NO_x from a single source during the term of the permit and 5 tons of NO_x at the facility during the term of the permit.

(3) One and six-tenths tons of the oxides of sulfur from a single source during the term of the permit and 8.0 tons of oxides of sulfur at the facility during the term of the permit.

(4) Six-tenths of a ton of PM₁₀ from a single source during the term of the permit and 3.0 tons of PM₁₀ at the facility during the term of the permit. This shall include emissions of a pollutant regulated under Section 112 of the Clean Air Act unless precluded by the Clean Air Act or 25 Pa. Code Article III.

(5) One ton of VOCs from a single source during the term of the permit and 5.0 tons of VOCs at the facility during the term of the permit. This shall include emissions of a pollutant regulated under Section 112 of the Clean Air Act unless precluded by the Clean Air Act or 25 Pa. Code Article III.

(c) In accordance with § 127.14, the permittee may install the following minor sources without the need for a plan approval:

(1) Air conditioning or ventilation systems not designed to remove pollutants generated or released from other sources.

(2) Combustion units rated at 2,500,000 or less Btu per hour of heat input.

**SECTION B. General Title V Requirements**

(3) Combustion units with a rated capacity of less than 10,000,000 Btu per hour heat input fueled by natural gas supplied by a public utility, liquefied petroleum gas or by commercial fuel oils which are No. 2 or lighter, viscosity less than or equal to 5.82 c St, and which meet the sulfur content requirements of 25 Pa. Code § 123.22 (relating to combustion units). For purposes of this permit, commercial fuel oil shall be virgin oil which has no reprocessed, recycled or waste material added.

(4) Space heaters which heat by direct heat transfer.

(5) Laboratory equipment used exclusively for chemical or physical analysis.

(6) Other sources and classes of sources determined to be of minor significance by the Department.

(d) This permit does not authorize de minimis emission increases if the emissions increase would cause one or more of the following:

(1) Increase the emissions of a pollutant regulated under Section 112 of the Clean Air Act except as authorized in Subparagraphs (b)(4) and (5) of this permit condition.

(2) Subject the facility to the prevention of significant deterioration requirements in 25 Pa. Code Chapter 127, Subchapter D and/or the new source review requirements in Subchapter E.

(3) Violate any applicable requirement of the Air Pollution Control Act, the Clean Air Act, or the regulations promulgated under either of the acts.

(4) Changes which are modifications under any provision of Title I of the Clean Air Act and emission increases which would exceed the allowable emissions level (expressed as a rate of emissions or in terms of total emissions) under the Title V permit.

(e) Unless precluded by the Clean Air Act or the regulations thereunder, the permit shield described in 25 Pa. Code § 127.516 (relating to permit shield) shall extend to the changes made under 25 Pa. Code § 127.449 (relating to de minimis emission increases).

(f) Emissions authorized under this permit condition shall be included in the monitoring, recordkeeping and reporting requirements of this permit.

(g) Except for de minimis emission increases allowed under this permit, 25 Pa. Code § 127.449, or sources and physical changes meeting the requirements of 25 Pa. Code § 127.14, the permittee is prohibited from making physical changes or engaging in activities that are not specifically authorized under this permit without first applying for a plan approval. In accordance with § 127.14(b), a plan approval is not required for the construction, modification, reactivation, or installation of the sources creating the de minimis emissions increase.

(h) The permittee may not meet de minimis emission threshold levels by offsetting emission increases or decreases at the same source.

#020 [25 Pa. Code §§ 127.11a & 127.215]**Reactivation of Sources**

(a) The permittee may reactivate a source at the facility that has been out of operation or production for at least one year, but less than or equal to five (5) years, if the source is reactivated in accordance with the requirements of 25 Pa. Code §§ 127.11a and 127.215. The reactivated source will not be considered a new source.

(b) A source which has been out of operation or production for more than five (5) years but less than 10 years may be reactivated and will not be considered a new source if the permittee satisfies the conditions specified in 25 Pa. Code § 127.11a(b).

#021 [25 Pa. Code §§ 121.9 & 127.216]**Circumvention**

(a) The owner of this Title V facility, or any other person, may not circumvent the new source review requirements of 25 Pa. Code Chapter 127, Subchapter E by causing or allowing a pattern of ownership or development, including the

**SECTION B. General Title V Requirements**

phasing, staging, delaying or engaging in incremental construction, over a geographic area of a facility which, except for the pattern of ownership or development, would otherwise require a permit or submission of a plan approval application.

(b) No person may permit the use of a device, stack height which exceeds good engineering practice stack height, dispersion technique or other technique which, without resulting in reduction of the total amount of air contaminants emitted, conceals or dilutes an emission of air contaminants which would otherwise be in violation of this permit, the Air Pollution Control Act or the regulations promulgated thereunder, except that with prior approval of the Department, the device or technique may be used for control of malodors.

#022 [25 Pa. Code §§ 127.402(d) & 127.513(1)]**Submissions**

(a) Reports, test data, monitoring data, notifications and requests for renewal of the permit shall be submitted to the:

Regional Air Program Manager
PA Department of Environmental Protection
(At the address given on the permit transmittal letter, or otherwise notified)

(b) Any report or notification for the EPA Administrator or EPA Region III should be addressed to:

Enforcement & Compliance Assurance Division
Air, RCRA and Toxics Branch (3ED21)
Four Penn Center
1600 John F. Kennedy Boulevard
Philadelphia, PA 19103-2852

The Title V compliance certification shall be emailed to EPA at R3_APD_Permits@epa.gov.

(c) An application, form, report or compliance certification submitted pursuant to this permit condition shall contain certification by a responsible official as to truth, accuracy, and completeness as required under 25 Pa. Code § 127.402(d). Unless otherwise required by the Clean Air Act or regulations adopted thereunder, this certification and any other certification required pursuant to this permit shall state that, based on information and belief formed after reasonable inquiry, the statements and information in the document are true, accurate and complete.

#023 [25 Pa. Code §§ 127.441(c) & 127.463(e); Chapter 139; & 114(a)(3), 504(b) of the CAA]**Sampling, Testing and Monitoring Procedures**

(a) The permittee shall perform the emissions monitoring and analysis procedures or test methods for applicable requirements of this Title V permit. In addition to the sampling, testing and monitoring procedures specified in this permit, the Permittee shall comply with any additional applicable requirements promulgated under the Clean Air Act after permit issuance regardless of whether the permit is revised.

(b) The sampling, testing and monitoring required under the applicable requirements of this permit, shall be conducted in accordance with the requirements of 25 Pa. Code Chapter 139 unless alternative methodology is required by the Clean Air Act (including §§ 114(a)(3) and 504(b)) and regulations adopted thereunder.

#024 [25 Pa. Code §§ 127.511 & Chapter 135]**Recordkeeping Requirements**

(a) The permittee shall maintain and make available, upon request by the Department, records of required monitoring information that include the following:

- (1) The date, place (as defined in the permit) and time of sampling or measurements.
- (2) The dates the analyses were performed.
- (3) The company or entity that performed the analyses.
- (4) The analytical techniques or methods used.

**SECTION B. General Title V Requirements**

(5) The results of the analyses.

(6) The operating conditions as existing at the time of sampling or measurement.

(b) The permittee shall retain records of the required monitoring data and supporting information for at least five (5) years from the date of the monitoring sample, measurement, report or application. Supporting information includes the calibration data and maintenance records and original strip-chart recordings for continuous monitoring instrumentation, and copies of reports required by the permit.

(c) The permittee shall maintain and make available to the Department upon request, records including computerized records that may be necessary to comply with the reporting, recordkeeping and emission statement requirements in 25 Pa. Code Chapter 135 (relating to reporting of sources). In accordance with 25 Pa. Code Chapter 135, § 135.5, such records may include records of production, fuel usage, maintenance of production or pollution control equipment or other information determined by the Department to be necessary for identification and quantification of potential and actual air contaminant emissions. If direct recordkeeping is not possible or practical, sufficient records shall be kept to provide the needed information by indirect means.

#025 [25 Pa. Code §§ 127.411(d), 127.442, 127.463(e) & 127.511(c)]**Reporting Requirements**

(a) The permittee shall comply with the reporting requirements for the applicable requirements specified in this Title V permit. In addition to the reporting requirements specified herein, the permittee shall comply with any additional applicable reporting requirements promulgated under the Clean Air Act after permit issuance regardless of whether the permit is revised.

(b) Pursuant to 25 Pa. Code § 127.511(c), the permittee shall submit reports of required monitoring at least every six (6) months unless otherwise specified in this permit. Instances of deviations (as defined in 25 Pa. Code § 121.1) from permit requirements shall be clearly identified in the reports. The reporting of deviations shall include the probable cause of the deviations and corrective actions or preventative measures taken, except that sources with continuous emission monitoring systems shall report according to the protocol established and approved by the Department for the source. The required reports shall be certified by a responsible official.

(c) Every report submitted to the Department under this permit condition shall comply with the submission procedures specified in Section B, Condition #022(c) of this permit.

(d) Any records, reports or information obtained by the Department or referred to in a public hearing shall be made available to the public by the Department except for such records, reports or information for which the permittee has shown cause that the documents should be considered confidential and protected from disclosure to the public under Section 4013.2 of the Air Pollution Control Act and consistent with Sections 112(d) and 114(c) of the Clean Air Act and 25 Pa. Code § 127.411(d). The permittee may not request a claim of confidentiality for any emissions data generated for the Title V facility.

#026 [25 Pa. Code § 127.513]**Compliance Certification**

(a) One year after the date of issuance of the Title V permit, and each year thereafter, unless specified elsewhere in the permit, the permittee shall submit to the Department and EPA Region III a certificate of compliance with the terms and conditions in this permit, for the previous year, including the emission limitations, standards or work practices. This certification shall include:

- (1) The identification of each term or condition of the permit that is the basis of the certification.
- (2) The compliance status.
- (3) The methods used for determining the compliance status of the source, currently and over the reporting period.
- (4) Whether compliance was continuous or intermittent.

(b) The compliance certification shall be postmarked or hand-delivered no later than thirty days after each anniversary of the date of issuance of this Title V Operating Permit, or on the submittal date specified elsewhere in the permit, to the Department in accordance with the submission requirements specified in Section B, Condition #022 of this permit. The Title V compliance certification shall be emailed to EPA at R3_APD_Permits@epa.gov.

**SECTION B. General Title V Requirements****#027 [25 Pa. Code § 127.3]****Operational Flexibility**

The permittee is authorized to make changes within the Title V facility in accordance with the following provisions in 25 Pa. Code Chapter 127 which implement the operational flexibility requirements of Section 502(b)(10) of the Clean Air Act and Section 6.1(i) of the Air Pollution Control Act:

- (1) Section 127.14 (relating to exemptions)
- (2) Section 127.447 (relating to alternative operating scenarios)
- (3) Section 127.448 (relating to emissions trading at facilities with federally enforceable emissions caps)
- (4) Section 127.449 (relating to de minimis emission increases)
- (5) Section 127.450 (relating to administrative operating permit amendments)
- (6) Section 127.462 (relating to minor operating permit amendments)
- (7) Subchapter H (relating to general plan approvals and operating permits)

#028 [25 Pa. Code §§ 127.441(d), 127.512(i) and 40 CFR Part 68]**Risk Management**

(a) If required by Section 112(r) of the Clean Air Act, the permittee shall develop and implement an accidental release program consistent with requirements of the Clean Air Act, 40 CFR Part 68 (relating to chemical accident prevention provisions) and the Federal Chemical Safety Information, Site Security and Fuels Regulatory Relief Act (P.L. 106-40).

(b) The permittee shall prepare and implement a Risk Management Plan (RMP) which meets the requirements of Section 112(r) of the Clean Air Act, 40 CFR Part 68 and the Federal Chemical Safety Information, Site Security and Fuels Regulatory Relief Act when a regulated substance listed in 40 CFR § 68.130 is present in a process in more than the listed threshold quantity at the Title V facility. The permittee shall submit the RMP to the federal Environmental Protection Agency according to the following schedule and requirements:

- (1) The permittee shall submit the first RMP to a central point specified by EPA no later than the latest of the following:
 - (i) Three years after the date on which a regulated substance is first listed under § 68.130; or,
 - (ii) The date on which a regulated substance is first present above a threshold quantity in a process.

(2) The permittee shall submit any additional relevant information requested by the Department or EPA concerning the RMP and shall make subsequent submissions of RMPs in accordance with 40 CFR § 68.190.

(3) The permittee shall certify that the RMP is accurate and complete in accordance with the requirements of 40 CFR Part 68, including a checklist addressing the required elements of a complete RMP.

(c) As used in this permit condition, the term "process" shall be as defined in 40 CFR § 68.3. The term "process" means any activity involving a regulated substance including any use, storage, manufacturing, handling, or on-site movement of such substances or any combination of these activities. For purposes of this definition, any group of vessels that are interconnected, or separate vessels that are located such that a regulated substance could be involved in a potential release, shall be considered a single process.

(d) If the Title V facility is subject to 40 CFR Part 68, as part of the certification required under this permit, the permittee shall:

- (1) Submit a compliance schedule for satisfying the requirements of 40 CFR Part 68 by the date specified in 40 CFR § 68.10(a); or,
- (2) Certify that the Title V facility is in compliance with all requirements of 40 CFR Part 68 including the registration and submission of the RMP.

**SECTION B. General Title V Requirements**

(e) If the Title V facility is subject to 40 CFR Part 68, the permittee shall maintain records supporting the implementation of an accidental release program for five (5) years in accordance with 40 CFR § 68.200.

(f) When the Title V facility is subject to the accidental release program requirements of Section 112(r) of the Clean Air Act and 40 CFR Part 68, appropriate enforcement action will be taken by the Department if:

(1) The permittee fails to register and submit the RMP or a revised plan pursuant to 40 CFR Part 68.

(2) The permittee fails to submit a compliance schedule or include a statement in the compliance certification required under Section B, Condition #026 of this permit that the Title V facility is in compliance with the requirements of Section 112(r) of the Clean Air Act, 40 CFR Part 68, and 25 Pa. Code § 127.512(i).

#029 [25 Pa. Code § 127.512(e)]**Approved Economic Incentives and Emission Trading Programs**

No permit revision shall be required under approved economic incentives, marketable permits, emissions trading and other similar programs or processes for changes that are provided for in this Title V permit.

#030 [25 Pa. Code §§ 127.516, 127.450(d), 127.449(f) & 127.462(g)]**Permit Shield**

(a) The permittee's compliance with the conditions of this permit shall be deemed in compliance with applicable requirements (as defined in 25 Pa. Code § 121.1) as of the date of permit issuance if either of the following applies:

(1) The applicable requirements are included and are specifically identified in this permit.

(2) The Department specifically identifies in the permit other requirements that are not applicable to the permitted facility or source.

(b) Nothing in 25 Pa. Code § 127.516 or the Title V permit shall alter or affect the following:

(1) The provisions of Section 303 of the Clean Air Act, including the authority of the Administrator of the EPA provided thereunder.

(2) The liability of the permittee for a violation of an applicable requirement prior to the time of permit issuance.

(3) The applicable requirements of the acid rain program, consistent with Section 408(a) of the Clean Air Act.

(4) The ability of the EPA to obtain information from the permittee under Section 114 of the Clean Air Act.

(c) Unless precluded by the Clean Air Act or regulations thereunder, final action by the Department incorporating a significant permit modification in this Title V Permit shall be covered by the permit shield at the time that the permit containing the significant modification is issued.

#031 [25 Pa. Code §135.3]**Reporting**

(a) The permittee shall submit by March 1 of each year an annual emissions report for the preceding calendar year. The report shall include information for all active previously reported sources, new sources which were first operated during the preceding calendar year, and sources modified during the same period which were not previously reported. All air emissions from the facility should be estimated and reported.

(b) A source owner or operator may request an extension of time from the Department for the filing of an annual emissions report, and the Department may grant the extension for reasonable cause.

#032 [25 Pa. Code §135.4]**Report Format**

Emissions reports shall contain sufficient information to enable the Department to complete its emission inventory. Emissions reports shall be made by the source owner or operator in a format specified by the Department.

**SECTION C. Site Level Requirements****I. RESTRICTIONS.****Emission Restriction(s).****# 001 [25 Pa. Code §123.1]****Prohibition of certain fugitive emissions**

No person may permit the emission into the outdoor atmosphere of fugitive air contaminants from a source other than the following:

- (1) Construction or demolition of buildings or structures
- (2) Grading, paving and maintenance of roads and streets
- (3) Use of roads and streets. Emissions from material in or on trucks, railroad cars and other vehicular equipment are not considered as emissions from use of roads and streets.
- (4) Clearing of land
- (5) Stockpiling of materials
- (6) Open burning operations
- (7) Sources and classes of sources other than those identified above, for which the permittee has obtained a determination from the Department that fugitive emissions from the source, after appropriate control, meet the following requirements:

- (a) The emissions are of minor significance with respect to causing air pollution
- (b) The emissions are not preventing or interfering with the attainment or maintenance of any ambient air quality standard

002 [25 Pa. Code §123.2]**Fugitive particulate matter**

No person may permit fugitive particulate matter to be emitted into the outdoor atmosphere from a source specified in Condition #001 above if the emissions are visible at the point the emissions pass outside the person's property.

003 [25 Pa. Code §123.31]**Limitations**

No person may permit the emission into the outdoor atmosphere of any malodorous air contaminants from any source in a manner that the malodors are detectable outside the property of the person on whose land the source is being operated.

004 [25 Pa. Code §123.41]**Limitations**

No person may permit the emission into the outdoor atmosphere of visible air contaminants in such a manner that the opacity of the emission is either of the following:

- (1) Equal to or greater than 20% for a period or periods aggregating more than three minutes in any 1 hour.
- (2) Equal to or greater than 60% at any time.

005 [25 Pa. Code §123.42]**Exceptions**

The emission limitations of 25 Pa. Code Section 123.41 shall not apply when:

- (1) The presence of uncombined water is the only reason for failure of the emission to meet the limitations;
- (2) The emission results from the operation of equipment used solely to train and test persons in observing the opacity of visible emissions;
- (3) The emission results from sources specified in 25 Pa. Code Section 123.1(a)(1)-(9).

006 [25 Pa. Code §127.441]**Operating permit terms and conditions.**

[Additional authority for this permit condition is derived from 40 CFR Part 63, Subpart GGG, Sections 63.1250 - 63.1260]

- (a) The permittee shall comply with all applicable "Standards: General" requirements for all sources at the facility subject to 40 CFR Part 63 Subpart GGG as specified in 40 CFR Part 63 Section 63.1252.
- (b) The permittee shall demonstrate compliance with all applicable requirements of 40 CFR Part 63 Subpart GGG Sections 63.1250 - 63.1260 for all sources at the facility subject to 40 CFR Part 63 Subpart GGG.

007 [25 Pa. Code §127.441]**Operating permit terms and conditions.**

[Additional authority for this permit condition is derived from 40 CFR Part 63, Subpart GGG, Sections 63.1250 - 63.1260]

**SECTION C. Site Level Requirements**

The permittee shall comply with all applicable "Standards: Process vents" requirements for all sources at the facility subject to 40 CFR Part 63 Subpart GGG as specified in 40 CFR Part 63 Section 63.1254.

008 [25 Pa. Code §127.441]**Operating permit terms and conditions.**

(a) In accordance with the plantwide applicability limit (PAL) provisions of 25 Pa. Code Section 127.218(g), the total combined volatile organic compound (VOC) emissions, including fugitive emissions, from the facility shall not exceed 61.84 tons in any 12 consecutive month period. The effective date of this VOC PAL is December 19, 2017 and the expiration date is December 19, 2027.

(b) In accordance with the plantwide applicability limit (PAL) provisions of 25 Pa. Code Section 127.218(g), emission calculations for compliance with the VOC PAL shall include emissions from startups, shutdowns and malfunctions.

009 [25 Pa. Code §127.441]**Operating permit terms and conditions.**

[Additional authority for this permit condition is derived from 40 CFR Part 63, Subpart GGG, Sections 63.1250 - 63.1260]

The permittee shall comply with all applicable "Standards: Wastewater" requirements for all sources at the facility subject to 40 CFR Part 63 Subpart GGG as specified in 40 CFR Part 63 Section 63.1256.

010 [25 Pa. Code §127.441]**Operating permit terms and conditions.**

[Additional authority for this permit condition is derived from 40 CFR Part 63, Subpart GGG, Sections 63.1250 - 63.1260]

The permittee shall comply with all applicable "Standards: Storage Tanks" requirements for all sources at the facility subject to 40 CFR Part 63 Subpart GGG as specified in 40 CFR Part 63 Section 63.1253.

011 [25 Pa. Code §127.441]**Operating permit terms and conditions.**

[Additional authority for this permit condition is derived from 40 CFR Part 63, Subpart GGG, Sections 63.1250 - 63.1260]

The permittee shall comply with all applicable "Standards: Equipment leaks" requirements for all sources at the facility subject to 40 CFR Part 63 Subpart GGG as specified in 40 CFR Part 63 Section 63.1255.

012 [40 CFR Part 63 NESHAPS for Source Categories §40 CFR 63.1254]**Subpart GGG - National Emission Standards for Pharmaceuticals Production****Standards: Process vents**

The permittee shall comply with all applicable "Standards: Surge control vessels and bottoms receivers" requirements for the affected sources subject to 40 CFR Part 63 Subpart GGG as specified in 40 CFR Part 63 Section 63.1254.

013 [40 CFR Part 63 NESHAPS for Source Categories §40 CFR 63.1255]**Subpart GGG - National Emission Standards for Pharmaceuticals Production****Standards: Equipment leaks**

The permittee shall comply with all applicable "Standards: Agitators in gas/vapor service and in light liquid service" requirements for the affected sources subject to 40 CFR Part 63 Subpart GGG as specified in 40 CFR Part 63 Section 63.1255(c).

014 [40 CFR Part 63 NESHAPS for Source Categories §40 CFR 63.162]**Subpart H--National Emission Standards for Organic Hazardous Air Pollutants for Equipment Leaks****Standards: General.**

For purposes of 40 CFR Part 63 Subpart GGG, the permittee shall comply with all applicable "Standards: General" requirements for the affected sources subject to 40 CFR Part 63 Subpart H as specified in 40 CFR Part 63 Sections 63.162 and 63.1255(b)(2).

015 [40 CFR Part 63 NESHAPS for Source Categories §40 CFR 63.163]**Subpart H--National Emission Standards for Organic Hazardous Air Pollutants for Equipment Leaks****Standards: Pumps in light liquid service.**

**SECTION C. Site Level Requirements**

The permittee shall comply with all applicable "Standards: Pumps in light liquid service" requirements for the affected sources subject to 40 CFR Part 63 Subpart GGG as specified in 40 CFR Part 63 Section 63.1255(c).

016 [40 CFR Part 63 NESHAPS for Source Categories §40 CFR 63.164]**Subpart H--National Emission Standards for Organic Hazardous Air Pollutants for Equipment Leaks****Standards: Compressors.**

For purposes of 40 CFR Part 63 Subpart GGG, the permittee shall comply with all applicable "Standards: Compressors" requirements for the affected sources subject to 40 CFR Part 63 Subpart H as specified in 40 CFR Part 63 Section 63.164 and 63.1255(b)(3).

017 [40 CFR Part 63 NESHAPS for Source Categories §40 CFR 63.165]**Subpart H--National Emission Standards for Organic Hazardous Air Pollutants for Equipment Leaks****Standards: Pressure relief devices in gas/vapor service.**

For purposes of 40 CFR Part 63 Subpart GGG, the permittee shall comply with all applicable "Standards: Pressure relief devices in gas/vapor service" requirements for the affected sources subject to 40 CFR Part 63 Subpart H as specified in 40 CFR Part 63 Section 63.165 and 63.1255(b)(3).

018 [40 CFR Part 63 NESHAPS for Source Categories §40 CFR 63.166]**Subpart H--National Emission Standards for Organic Hazardous Air Pollutants for Equipment Leaks****Standards: Sampling connection systems.**

For purposes of 40 CFR Part 63 Subpart GGG, the permittee shall comply with all applicable "Standards: Sampling connection systems" requirements for the affected sources subject to 40 CFR Part 63 Subpart H as specified in 40 CFR Part 63 Section 63.166 and 63.1255(b)(3).

019 [40 CFR Part 63 NESHAPS for Source Categories §40 CFR 63.167]**Subpart H--National Emission Standards for Organic Hazardous Air Pollutants for Equipment Leaks****Standards: Open-ended valves or lines.**

The permittee shall comply with all applicable "Standards: Open-ended valves or lines" requirements for the affected sources subject to 40 CFR Part 63 Subpart GGG as specified in 40 CFR Part 63 Section 63.1255(d).

020 [40 CFR Part 63 NESHAPS for Source Categories §40 CFR 63.168]**Subpart H--National Emission Standards for Organic Hazardous Air Pollutants for Equipment Leaks****Standards: Valves in gas/vapor service and in light liquid service.**

The permittee shall comply with all applicable "Standards: Valves in gas/vapor service and in light liquid service" requirements for the affected sources subject to 40 CFR Part 63 Subpart GGG as specified in 40 CFR Part 63 Section 63.1255(e).

021 [40 CFR Part 63 NESHAPS for Source Categories §40 CFR 63.169]**Subpart H--National Emission Standards for Organic Hazardous Air Pollutants for Equipment Leaks****Standards: Pumps, valves, connectors, and agitators in heavy liquid service; instrumentation systems; and pressure re**

For purposes of 40 CFR Part 63 Subpart GGG, the permittee shall comply with all applicable "Standards: Pumps, valves, connectors and agitators in heavy liquid service; instrumentation systems and pressure relief devices in light liquid service" requirements for the affected sources subject to 40 CFR Part 63 Subpart H as specified in 40 CFR Part 63 Section 63.169 and 63.1255(b)(3).

022 [40 CFR Part 63 NESHAPS for Source Categories §40 CFR 63.171]**Subpart H--National Emission Standards for Organic Hazardous Air Pollutants for Equipment Leaks****Standards: Delay of repair.**

For purposes of 40 CFR Part 63 Subpart GGG, the permittee shall comply with all applicable "Standards: Delay of repair" requirements for all sources at the facility subject to 40 CFR Part 63 Subpart H as specified in 40 CFR Part 63 Section 63.171 and 63.1255(b)(4).

023 [40 CFR Part 63 NESHAPS for Source Categories §40 CFR 63.172]**Subpart H--National Emission Standards for Organic Hazardous Air Pollutants for Equipment Leaks****Standards: Closed-vent systems and control devices.**

For purposes of 40 CFR Part 63 Subpart GGG, the permittee shall comply with all applicable "Standards: Closed-vent

**SECTION C. Site Level Requirements**

systems and control devices" requirements for the affected sources subject to 40 CFR Part 63 Subpart H as specified in 40 CFR Part 63 Section 63.172 and 63.1255(b)(4).

024 [40 CFR Part 63 NESHAPS for Source Categories §40 CFR 63.174]**Subpart H--National Emission Standards for Organic Hazardous Air Pollutants for Equipment Leaks
Standards: Connectors in gas/vapor service and in light liquid service.**

For purposes of 40 CFR Part 63 Subpart GGG, the permittee shall comply with all applicable "Standards: Closed-vent systems and control devices" requirements for the affected sources subject to 40 CFR Part 63 Subpart H as specified in 40 CFR Part 63 Section 63.174 and 63.1255(b)(4).

025 [40 CFR Part 63 NESHAPS for Source Categories §40 CFR 63.177]**Subpart H--National Emission Standards for Organic Hazardous Air Pollutants for Equipment Leaks
Alternative means of emission limitation: General.**

For purposes of 40 CFR Part 63 Subpart GGG, the permittee shall comply with all applicable "Standards: Closed-vent systems and control devices" requirements for the affected subject to 40 CFR Part 63 Subpart H as specified in 40 CFR Part 63 Section 63.177 and 63.1255(b)(3).

026 [40 CFR Part 63 NESHAPS for Source Categories §40 CFR 63.178]**Subpart H--National Emission Standards for Organic Hazardous Air Pollutants for Equipment Leaks
Alternative means of emission limitation: Batch processes.**

The permittee shall comply with all applicable "Alternative means of emission limitation: Batch Processes" requirements for all sources at the facility subject to 40 CFR Part 63 Subpart H as specified in 40 CFR Part 63 Section 63.178.

027 [40 CFR Part 63 NESHAPS for Source Categories §40 CFR 63.179]**Subpart H--National Emission Standards for Organic Hazardous Air Pollutants for Equipment Leaks
Alternative means of emission limitation: Enclosed-vented process units.**

For purposes of 40 CFR Part 63 Subpart GGG, the permittee shall comply with all applicable "Standards: Closed-vent systems and control devices" requirements for the affected sources subject to 40 CFR Part 63 Subpart H as specified in 40 CFR Part 63 Section 63.179 and 63.1255(b)(3).

028 [40 CFR Part 63 NESHAPS for Source Categories §40 CFR 63.192]**Subpart I--National Emission Standards for Organic Hazardous Air Pollutants for Certain Processes Subject to the
Negotiated Regulation for Equipment Leaks
Standard.**

(a) The permittee shall comply with all applicable standards for all sources at the facility subject to 40 CFR Part 63 Subpart I as specified in 40 CFR Part 63 Section 63.192.

(b) Pursuant to the provisions specified in 40 CFR § 63.1250(h)(4), after the compliance dates specified in this section, the permittee may elect to comply with either the provisions of § 63.1255 or the provisions of subpart H of this part for all such equipment. The owner or operator shall identify in the Notification of Compliance Status report required by § 63.1260(f) the provisions with which the owner elects to comply.

Fuel Restriction(s).**# 029 [25 Pa. Code §127.441]****Operating permit terms and conditions.**

[Compliance with this condition ensures compliance with the requirements of 25 Pa. Code Section 123.22(a)(2)(i).]

The #2 and lighter fuel oil used in combustion sources at the facility shall not exceed 0.0015% sulfur by weight.

II. TESTING REQUIREMENTS.**# 030 [25 Pa. Code §127.441]****Operating permit terms and conditions.**

[Additional authority for this permit condition is derived from 40 CFR Part 63, Subpart GGG, Sections 63.1250 - 63.1260]

The permittee shall comply with all applicable test methods and compliance procedures requirements for all sources at the facility subject to 40 CFR Part 63 Subpart GGG as specified in 40 CFR Part 63 Section 63.1257.

**SECTION C. Site Level Requirements****# 031 [25 Pa. Code §127.441]****Operating permit terms and conditions.**

The permittee shall perform tests (in accordance with the provisions of 25 Pa. Code Chapter 139) or provide a fuel certification report of the percent sulfur by weight for each delivery of the #2 and lighter fuel oil delivered to this facility,

OR

the permittee shall provide a fuel certification report obtained from the supplier once a year stating that the sulfur percentage for each shipment of #2 and lighter fuel oil delivered to the facility during the year shall not exceed 0.0015% sulfur by weight.

032 [25 Pa. Code §127.441]**Operating permit terms and conditions.**

If at any time the Department has cause to believe that air contaminant emissions from any source at the facility may be in excess of the limitations specified in any condition contained in this permit or specified in, or established pursuant to, any applicable rule or regulation contained in 25 Pa. Code Chapters 121 - 145, the permittee shall be required to conduct whatever tests are deemed necessary by the Department to determine the actual emission rate(s). Such testing shall be conducted in accordance with the provisions of 25 Pa. Code Chapter 139, where applicable, and in accordance with any restrictions or limitations established by the Department at such time as it notifies the permittee that testing is required.

033 [25 Pa. Code §127.441]**Operating permit terms and conditions.**

(a) Pursuant to 25 Pa. Code § 139.3, at least 90 calendar days prior to commencing a EPA reference method testing program, a test protocol shall be submitted to the Department for review and approval. Electronic copies shall be sent to the Northcentral Regional Office Air Quality Program Manager and the PSIMS Administrator in Central Office. The test protocol shall meet all applicable requirements specified in the most current version of the Department's Source Testing Manual.

(b) Pursuant to 25 Pa. Code § 139.3, at least 15 calendar days prior to commencing an emission testing program, notification as to the date and time of testing shall be given to the Northcentral Regional Office. Notification shall also be sent to the Division of Source Testing and Monitoring. Notification shall not be made without prior receipt of a protocol acceptance letter from the Department.

(c) If applicable, pursuant to 40 CFR § 60.8(a), 40 CFR § 61.13(f) and 40 CFR § 63.7(g), complete test reports shall be submitted to the Department no later than 60 calendar days after completion of the on-site testing portion of an EPA reference method test program.

(d) Pursuant to 25 Pa. Code § 139.53(b) a complete test report shall include a summary of the emission results on the first page of the report indicating if each pollutant measured is within permitted limits and a statement of compliance or noncompliance with all applicable permit conditions. The summary results will include, at a minimum, the following information:

1. A statement that the owner or operator has reviewed the report from the emissions testing body and agrees with the findings.
2. Permit number(s) and condition(s) which are the basis for the evaluation.
3. Summary of results with respect to each applicable permit condition.
4. Statement of compliance or non-compliance with each applicable permit condition.

(e) Pursuant to 25 Pa. Code § 139.3, all submittals shall meet all applicable requirements specified in the most current version of the Department's Source Testing Manual.

(f) All testing shall be performed in accordance with the provisions of Chapter 139 of the Rules and Regulations of the Department of Environmental Protection.

(g) Pursuant to 25 Pa. Code § § 139.53(a)(1) and 139.53(a)(3), electronic copies of all submittals, besides notifications, shall be sent to the Northcentral Regional Office Air Quality Program Manager, with deadlines verified. In addition, an electronic copy shall be sent to the PSIMS Administrator in Central Office. Email addresses are provided on the PA DEP website.

(h) The permittee shall insure all federal reporting requirements contained in the applicable subpart of 40 CFR are followed, including timelines more stringent than those contained herein. In the event of an inconsistency or any conflicting requirements between state and the federal, the most stringent provision, term, condition, method or rule shall be used by

**SECTION C. Site Level Requirements**

default.

034 [25 Pa. Code §139.1]**Sampling facilities.**

Upon the request of the Department, the permittee shall provide adequate sampling ports, safe sampling platforms and adequate utilities for the performance by the Department of tests on such source. The Department will set forth, in the request, the time period in which the facilities shall be provided as well as the specifications for such facilities.

035 [25 Pa. Code §139.11]**General requirements.**

(a) As specified in 25 Pa. Code Section 139.11(1), performance tests shall be conducted while the source is operating at maximum routine operating conditions or under such other conditions, within the capacity of the equipment, as may be requested by the Department.

(b) As specified in 25 Pa. Code Section 139.11(2), the Department will consider test results for approval where sufficient information is provided to verify the source conditions existing at the time of the test and where adequate data is available to show the manner in which the test was conducted. Information submitted to the Department shall include, as a minimum, all of the following:

- (1) A thorough source description, including a description of any air cleaning devices and the flue.
- (2) Process conditions, for example, the charging rate of raw material or rate of production of final product, boiler pressure, oven temperature and other conditions which may affect emissions from the process.
- (3) The location of sampling ports.
- (4) Effluent characteristics, including velocity, temperature, moisture content, gas density (percentage of CO, CO₂, O₂ and N₂), static and barometric pressures.
- (5) Sample collection techniques employed, including procedures used, equipment descriptions and data to verify that isokinetic sampling for particulate matter collection occurred and that acceptable test conditions were met.
- (6) Laboratory procedures and results.
- (7) Calculated results.

036 [40 CFR Part 63 NESHAPS for Source Categories §40 CFR 63.180]**Subpart H--National Emission Standards for Organic Hazardous Air Pollutants for Equipment Leaks
Test methods and procedures.**

For purposes of 40 CFR Part 63 Subpart GGG, the permittee shall comply with all applicable "Standards: Closed-vent systems and control devices" requirements for the affected sources subject to 40 CFR Part 63 Subpart H as specified in 40 CFR Part 63 Section 63.180 and 63.1255(b)(3).

037 [40 CFR Part 63 NESHAPS for Source Categories §40 CFR 63.192]**Subpart I--National Emission Standards for Organic Hazardous Air Pollutants for Certain Processes Subject to the Negotiated Regulation for Equipment Leaks
Standard.**

The permittee shall comply with all applicable performance test requirements for all sources at the facility subject to 40 CFR Part 63 Subpart I as specified in 40 CFR Part 63 Section 63.192.

III. MONITORING REQUIREMENTS.**# 038 [25 Pa. Code §123.43]****Measuring techniques**

Visible emissions may be measured using either of the following:

- (1) A device approved by the Department and maintained to provide accurate opacity measurements.
- (2) Observers, trained and qualified, to measure plume opacity with the naked eye or with the aid of any devices approved by the Department.

039 [25 Pa. Code §127.441]**Operating permit terms and conditions.**

**SECTION C. Site Level Requirements**

[Additional authority for this permit condition is derived from 40 CFR Part 63, Subpart GGG, Sections 63.1250 - 63.1260]

The permittee shall comply with all applicable monitoring requirements for all sources at the facility subject to 40 CFR Part 63 Subpart GGG as specified in 40 CFR Part 63 Section 63.1258.

040 [25 Pa. Code §127.441]**Operating permit terms and conditions.**

The permittee shall meet at least one of the following minimum data availability requirements for required monitoring unless other data availability requirements are stipulated elsewhere in the 25 Pa. Code, in a plan approval or permit condition, the Department's Continuous Source Monitoring (CSM) Manual, or in an order issued under Section 4 of the Air Pollution Control Act. For purposes of calculating data availability, "process down" time as specified in the Department's CSM Manual shall be considered valid time.

- (i) In each calendar month, at least 90% of the time periods for which an emission standard or an operational parameter applies shall be valid as set forth in the Department's CSM Manual.
- (ii) In each calendar quarter, at least 95% of the hours shall be valid as specified in the Department's CSM Manual.

041 [25 Pa. Code §127.441]**Operating permit terms and conditions.**

(a) The permittee shall conduct a weekly inspection of the facility during daylight hours while the facility is operating to detect visible emissions, visible fugitive emissions and malodors. Weekly inspections are necessary to determine:

- (1) The presence of visible emissions.
- (2) The presence of visible fugitive emissions.
- (3) The presence of malodors beyond the boundaries of the facility.

(b) All detected visible emissions, visible fugitive emissions or malodors that have the potential to exceed applicable limits shall be reported to the manager of the facility.

042 [25 Pa. Code §127.441]**Operating permit terms and conditions.**

In accordance with the plantwide applicability limit (PAL) provisions of 25 Pa. Code Section 127.218(g), the permittee shall monitor all VOC emissions at the facility in accordance with 25 Pa. Code Section 127.218(m).

IV. RECORDKEEPING REQUIREMENTS.**# 043 [25 Pa. Code §127.441]****Operating permit terms and conditions.**

[Additional authority for this permit condition is derived from 40 CFR Part 63, Subpart GGG, Sections 63.1250 - 63.1260]

(a) The permittee shall comply with all applicable recordkeeping requirements for all sources at the facility subject to 40 CFR Part 63 Subpart GGG as specified in 40 CFR Part 63 Section 63.1259.

(b) The permittee shall maintain comprehensive records of the following information for all of the processes and storage tanks (included herein under Source IDs 140 and 155) that are elected by the facility to be included in the emissions averaging calculation and qualify to be included in emissions averaging calculations according to the criteria specified in 40 CFR § 63.1252(d) including the restriction to only include processes and storage tanks subject to the numerical standards as specified in 40 CFR § 63.1254(a)(1)(i) for processes and 40 CFR § 63.1253(c)(1)(i) for storage tanks.

(1) An Implementation Plan.

(A) An Implementation Plan shall include all of the following information derived from the applicable requirements specified in the provisions of 40 CFR § 63.1259(e), paragraphs (e)(1)(i) through (v), relating to records of emissions averaging.

(A1) The identification of all process vents and storage tanks in each emissions average.

(A2) The uncontrolled and controlled emissions of HAP and the overall percent reduction efficiency as determined in 40 CFR §§ 63.1257(g)(1) through (4) or 63.1257(h)(1) through (3) as applicable.

(A3) The calculations used to obtain the uncontrolled and controlled HAP emissions and the overall percent reduction efficiency.

**SECTION C. Site Level Requirements**

(A4) The estimated values for all parameters required to be monitored under 40 CFR § 63.1258(f) for each process and storage tank included in an average.

(A5) A statement that the compliance demonstration, monitoring, inspection, recordkeeping and reporting requirements required by the Title V Operating Permit 49-00007 terms and conditions that include the applicable provisions specified in 40 CFR §§ 63.1257(g) and (h), 63.1258(f), and 63.1260(k) will be implemented beginning on the date of compliance (or the next effective date after a change to the implementation plan for emissions averaging).

(c) Information that satisfies the applicable recordkeeping requirement specified in 40 CFR § 63.1259(e)(3).

044 [25 Pa. Code §127.441]**Operating permit terms and conditions.**

The permittee shall keep records of tests or fuel certification reports of the percent sulfur by weight for each delivery of the #2 and lighter fuel oil delivered to the facility,

OR

The permittee shall keep records of fuel certification reports obtained yearly from the fuel oil supplier stating that the sulfur percentage for each shipment of #2 and lighter fuel oil delivered to the facility during the year shall not exceed 0.0015 % sulfur by weight.

045 [25 Pa. Code §127.441]**Operating permit terms and conditions.**

In accordance with the plantwide applicability limit (PAL) provisions of 25 Pa. Code Section 127.218(g), the permittee shall keep records of the monthly emissions of VOCs from the facility and the supporting calculations/documentation to verify compliance with the VOC PAL (includes total annual emissions in TPY based on a 12-month rolling total for each month in the reporting period), including a determination of the 12-month rolling total emissions from each emissions unit.

The records shall be retained for a minimum of five years and shall be made available to the Department upon request.

046 [25 Pa. Code §127.441]**Operating permit terms and conditions.**

(a) The permittee shall maintain a logbook of the facility inspections performed. The logbook shall include the name of the company representative performing the inspection, the date and time of inspections, any instances of exceedances of visible emissions limitations, visible fugitive emissions limitations and malodorous air emissions limitations, and the name of the manager informed if a potential exceedance is observed. The permittee shall also record any and all corrective action(s) taken to abate each recorded deviation to prevent future occurrences.

(b) These records shall be retained for a minimum of 5 years and shall be made available to the Department upon request.

047 [25 Pa. Code §135.5]**Recordkeeping**

The permittee shall maintain and make available upon request by the Department records including computerized records that may be necessary to comply with Sections 135.3 and 135.21 (relating to reporting; and emission statements). These may include records of production, fuel usage, maintenance of production or pollution control equipment or other information determined by the Department to be necessary for identification and quantification of potential and actual air contaminant emissions.

048 [40 CFR Part 63 NESHAPS for Source Categories §40 CFR 63.192]**Subpart I--National Emission Standards for Organic Hazardous Air Pollutants for Certain Processes Subject to the Negotiated Regulation for Equipment Leaks Standard.**

The permittee shall comply with all applicable recordkeeping requirements for all source at the facility subject to 40 CFR Part 63 Subpart I as specified in 40 CFR Part 63 Section 63.192.

049 [40 CFR Part 63 NESHAPS for Source Categories §40 CFR 63.7881]**Subpart GGGGG - National Emission Standards for Hazardous Air Pollutants: Site Remediation Am I subject to this subpart?**

(a) In accordance with 40 CFR 63.7881(c), the permittee shall maintain records verifying that the total quantity of the HAPs listed in Table 1 of Subpart GGGGG that are contained in the remediation material excavated, extracted, pumped, or

**SECTION C. Site Level Requirements**

- otherwise removed during all of the site remediations conducted at this facility are less than 1 megagram (Mg) annually.
- (b) Compliance with the 1 Mg limit in (a) above exempts site remediation activities from all other requirements found in Subpart GGGGG. This exemption applies the 1 Mg limit on a facility-wide, annual basis, and there is no restriction to the number of site remediations that can be conducted during this period.
- (c) These records shall be maintained onsite for at least five years and be made available to the Department upon request.

V. REPORTING REQUIREMENTS.**# 050 [25 Pa. Code §127.441]****Operating permit terms and conditions.**

[Additional authority for this permit condition is derived from 40 CFR Part 63, Subpart GGG, Sections 63.1250 - 63.1260.]

- (a) The permittee shall comply with all applicable reporting requirements for all sources at the facility subject to 40 CFR Part 63 Subpart GGG as specified in 40 CFR Part 63 Section 63.1260.
- (b) The permittee shall comply with the applicable reporting requirements for emissions averaging as specified in 40 CFR Section 63.1260(k)
- (c) All reports required by 40 CFR Part 63 Subpart GGG shall be submitted to the Department and the EPA.

051 [25 Pa. Code §127.441]**Operating permit terms and conditions.**

In accordance with the plantwide applicability limit (PAL) provisions of 25 Pa. Code Section 127.218(g), the permittee shall submit semiannual reports of the following:

- (a) The monthly emissions of VOCs from the facility and the supporting calculations/documentation to verify compliance with the VOC PAL (includes total annual emissions in TPY based on a 12-month rolling total for each month in the reporting period).
- (b) A list of the emissions units modified or added to the major facility during the preceding 6-month period.
- (c) The number, duration and cause of deviations or monitoring malfunctions, other than the time associated with zero and span calibration checks, and the corrective action taken.
- (d) A notification of a shutdown of a monitoring system, whether the shutdown was permanent or temporary, the reason for the shutdown, the anticipated date that the monitoring system will be fully operational or replaced with another monitoring system, whether the emissions unit monitored by the monitoring system continued to operate, and the calculation of the emissions of the pollutant or the number determined by the method included in the permit under subsection (m)(10).
- (e) A statement signed by a responsible official of the company that owns or operates the facility certifying the truth, accuracy and completeness of the information provided in the report.

The semiannual reports shall be submitted to the Department no later than March 1 and September 1.

052 [25 Pa. Code §127.441]**Operating permit terms and conditions.**

In accordance with the plantwide applicability limit (PAL) provisions of 25 Pa. Code Section 127.218(g), the permittee shall submit reports of deviations and exceedances of the PAL requirements in accordance with 25 Pa. Code Section 127.218(o)(3).

053 [25 Pa. Code §127.442]**Reporting requirements.**

- (a) The permittee shall report malfunctions, emergencies or incidents of excess emissions to the Department. A malfunction is any sudden, infrequent, and not reasonably preventable failure of air pollution control equipment, process equipment, or a process to operate in a normal or usual manner. An emergency is any situation arising from sudden and reasonably unforeseeable events beyond the control of the owner or operator of a facility which requires immediate corrective action to restore normal operation and which causes the emission source to exceed emissions, due to unavoidable increases in emissions attributable to the situation. An emergency shall not include situations caused by improperly designed equipment, lack of preventive maintenance, careless or improper operation, or operator error.
- (b) When the malfunction, emergency or incident of excess emissions poses an imminent danger to the public health, safety, welfare, or environment, it shall be reported to the Department and the County Emergency Management Agency by telephone within one (1) hour after the discovery of the malfunction, emergency or incident of excess emissions. The owner or operator shall submit a written or emailed report of instances of such malfunctions, emergencies or incidents

**SECTION C. Site Level Requirements**

of excess emissions to the Department within three (3) business days of the telephone report.

(c) The report shall describe the following:

1. name, permit or authorization number, and location of the facility,
2. nature and cause of the malfunction, emergency or incident,
3. date and time when the malfunction, emergency or incident was first observed,
4. expected duration of excess emissions,
5. estimated rate of emissions,
6. corrective actions or preventative measures taken.

(d) Any malfunction, emergency or incident of excess emissions that is not subject to the notice requirements of paragraph (b) of this condition shall be reported to the Department by telephone within 24 hours (or by 4:00 PM of the next business day, whichever is later) of discovery and in writing or by e-mail within five (5) business days of discovery. The report shall contain the same information required by paragraph (c), and any permit specific malfunction reporting requirements.

(e) During an emergency an owner or operator may continue to operate the source at their discretion provided they submit justification for continued operation of a source during the emergency and follow all the notification and reporting requirements in accordance with paragraphs (b)-(d), as applicable, including any permit specific malfunction reporting requirements.

(f) Reports regarding malfunctions, emergencies or incidents of excess emissions shall be submitted to the appropriate DEP Regional Office Air Program Manager.

(g) Any emissions resulted from malfunction or emergency are to be reported in the annual emissions inventory report, if the annual emissions inventory report is required by permit or authorization.

054 [25 Pa. Code §135.21]**Emission statements**

(a) The permittee shall provide the Department with a statement (AIMS) of each stationary source in a form as prescribed by the Department, showing the actual emissions of oxides of nitrogen and volatile organic compounds (VOCs) from the permitted facility for each reporting period, a description of the method used to calculate the emissions and the time period over which the calculation is based.

(b) The annual emission statements (AIMS) are due by March 1 for the preceding calendar year and shall contain a certification by a company officer or the plant manager that the information contained in the statement is accurate. The Emission Statement shall provide data consistent with requirements and guidance developed by the EPA.

(c) The Department may require more frequent submittals if the Department determines that one or more of the following applies:

(1) A more frequent submission is required by the EPA.

(2) Analysis of the data on a more frequent basis is necessary to implement the requirements of the Air Pollution Control Act.

055 [25 Pa. Code §135.3]**Reporting**

(a) A person who owns or operates a source to which 25 Pa. Code Chapter 135 applies, and who has previously been advised by the Department to submit a source report, shall submit by March 1 of each year an Annual Air Information Management Systems (AIMS) Emissions report for the preceding calendar year. The report shall include information for all previously reported sources, new sources which were first operated during the preceding calendar year and sources modified during the same period which were not previously reported.

(b) A person who receives initial notification by the Department that an Annual Air Information Management Systems (AIMS) Emissions report is necessary, shall submit an initial Annual Air Information Management Systems (AIMS) Emissions report within sixty (60) days after receiving the notification or by March 1 of the year following the year for which the report is required, whichever is later.

(c) The permittee may request an extension of time from the Department for the filing of an Annual Air Information Management Systems (AIMS) Emissions report, and the Department may grant the extension for reasonable cause.

**SECTION C. Site Level Requirements****# 056 [40 CFR Part 63 NESHAPS for Source Categories §40 CFR 63.192]****Subpart I--National Emission Standards for Organic Hazardous Air Pollutants for Certain Processes Subject to the Negotiated Regulation for Equipment Leaks Standard.**

The permittee shall comply with all applicable reporting requirements for all source at the facility subject to 40 CFR Part 63 Subpart I as specified in 40 CFR Part 63 Section 63.192.

VI. WORK PRACTICE REQUIREMENTS.**# 057 [25 Pa. Code §123.1]****Prohibition of certain fugitive emissions**

For any source specified in 25 Pa. Code Section 123.1 subsection(s) (a)(1)-(7) or (a)(9), the permittee shall take all reasonable actions to prevent particulate matter from becoming airborne. These actions shall include, but not be limited to, the following:

- (1) Use, where possible, of water or chemicals for control of dust in the demolition of buildings or structures, construction operations, the grading of roads or the clearing of land.
- (2) Application of asphalt, oil, or suitable chemicals on dirt roads, material stockpiles and other surfaces which may give rise to airborne dusts.
- (3) Paving and maintenance of roadways.
- (4) Prompt removal of earth or other material from paved streets onto which earth or other material has been transported by trucking or earth moving equipment, erosion by water, or other means.

VII. ADDITIONAL REQUIREMENTS.**# 058 [25 Pa. Code §127.441]****Operating permit terms and conditions.**

(a) The following emission estimation methods may be used to estimate emissions for sources to verify compliance with the emission limitations in this operating permit:

- (1) Combustion source emissions may be estimated using AP-42 emission factors, vendor emission factors, stack test results, or continuous monitoring systems.
- (2) Emissions from Source ID. 101 may be estimated using the EPA TOXCHEM model.
- (3) Pharmaceutical production process vent emissions (Source ID 140) may be estimated using the 1978 CTG equations if no current emission factors are available.
- (4) Filling and breathing losses from bulk storage vessels at the facility may be estimated using equations from Section 7 of AP-42 for breathing and working losses from bulk storage tanks.
- (5) Emissions from Sources ID. 180 and 250 may be estimated using engineering calculations and maximum projected handling levels.
- (6) Emissions from Source ID. 260 may be estimated using published emission factors for fume hoods.

(b) The Department retains the right to reject any or all estimates generated by the use of these estimation techniques as a demonstration of compliance with any emission limit specified in any condition contained in this operating permit or any limitation specified in, or established pursuant to, any applicable rule or regulation contained in 25 Pa. Code Chapters 121 - 145 if the Department has cause to believe that more accurate means exist to quantify the respective emissions. The most recent and accurate emission factors and Department-approved estimation methods will be acceptable to the Department.

059 [25 Pa. Code §127.441]**Operating permit terms and conditions.**

[Additional authority for this permit condition is derived from 40 CFR Part 63, Subpart GGG, Sections 63.1250 - 63.1260]

The facility is subject to Subpart GGG of the National Emission Standards for Hazardous Air Pollutants for Source Categories, Pharmaceuticals Production, 40 CFR Part 63 Sections 63.1250 - 63.1260. The permittee shall comply with all applicable requirements of this Subpart of the National Emission Standards for Hazardous Air Pollutants for Source Categories, including any recordkeeping and reporting requirements.

**SECTION C. Site Level Requirements****# 060 [25 Pa. Code §127.441]****Operating permit terms and conditions.**

[Additional authority for this permit condition is derived from 40 CFR Part 63 Section 63.1260(e).]

- (a) The permittee has submitted a pre-compliance report to the Department as required by 40 CFR Part 63 Section 63.1260(e). The pre-compliance report dated December 14, 2001 was found to be satisfactory to the Department.
- (b) The permittee shall follow all monitoring, recordkeeping, and reporting procedures outlined in the pre-compliance report submitted to the Department, shall be followed to demonstrate compliance with the requirements of 40 CFR Part 63 Subparts GGG with the exception that all emission estimation assumptions specified in 40 CFR Part 63 Sections 63.1257(d)(i)(A) - (H) be used by the permittee to estimate emissions from sources.

061 [25 Pa. Code §127.441]**Operating permit terms and conditions.**

- (a) The facility is subject to 40 CFR Part 82, Subpart E, The Labeling of Products Using Ozone-Depleting Substances. The permittee shall comply with all the applicable requirements specified in 40 CFR Sections 82.100 through 82.124.
- (b) The facility is subject to 40 CFR Part 82, Subpart F, Recycling and Emissions Reduction. The permittee shall comply with all the applicable requirements specified in 40 CFR Sections 82.150 through 82.166.
- (c) The facility is subject to 40 CFR Part 82, Subpart G, Significant New Alternatives Policy Program. The permittee shall comply with all the applicable requirements specified in 40 CFR Sections 82.170 through 82.184.

062 [25 Pa. Code §127.441]**Operating permit terms and conditions.**

The facility is subject to 40 CFR Part 61, Subpart M, National Emission Standard for Asbestos. The permittee shall comply with all the applicable requirements specified in 40 CFR Sections 61.140 through 61.157.

063 [25 Pa. Code §127.441]**Operating permit terms and conditions.**

[Additional authority for this permit condition is derived from 40 CFR Part 63 Subpart GGG Sections 63.1250 - 63.1260]

The permittee shall comply with all applicable requirements specified in Table 1 to Subpart GGG of Part 63, "General Provisions Applicability to Subpart GGG" for all the sources at the facility subject to 40 CFR Part 63 Subpart GGG.

064 [25 Pa. Code §127.441]**Operating permit terms and conditions.**

- (a) In accordance with the plantwide applicability limit (PAL) provisions of 25 Pa. Code Section 127.218(g), if the permittee applies to renew the VOC PAL in accordance with 25 Pa. Code Section 127.218(k) before the end of the PAL effective period, the PAL permit does not expire at the end of the PAL effective period. The PAL permit remains in effect until the Department issues a revised PAL permit.
- (b) In accordance with the plantwide applicability limit (PAL) provisions of 25 Pa. Code Section 127.218(g), upon expiration of the PAL permit, the permittee is subject to the requirements of 25 Pa. Code Section 127.218(j).

065 [25 Pa. Code §127.441]**Operating permit terms and conditions.**

In accordance with the plantwide applicability limit (PAL) provisions of 25 Pa. Code Section 127.218(g), the emissions from a new source that requires a plan approval shall be the minimum attainable through the use of BAT. A physical change or change in method of operation at an existing emissions unit will not be subject to BAT requirements of this chapter unless the emissions unit is modified so that the fixed capital cost of new components exceeds 50% of the fixed capital cost that would be required to construct a comparable entirely new emissions unit.

066 [25 Pa. Code §127.441]**Operating permit terms and conditions.**

[Additional authority for this permit condition is derived from 40 CFR Part 63, Subpart GGG, Sections 63.1250 - 63.1260]

- (a) The permittee shall comply with all applicable requirements of 40 CFR Part 63, Subpart GGG, Sections 63.1250 - 63.1260, for all sources at the facility subject to 40 CFR Part 63 Subpart GGG.
- (b) In accordance with the provisions specified in 40 CFR Part 63, Section 63.1250(f)(4), the permittee shall comply with all applicable requirements of 40 CFR Part 63, Subpart GGG, Sections 63.1250 - 63.1260.

**SECTION C. Site Level Requirements****# 067 [25 Pa. Code §129.14]****Open burning operations**

No person may permit the open burning of material at this facility unless in accordance with 25 Pa. Code Section 129.14.

VIII. COMPLIANCE CERTIFICATION.

No additional compliance certifications exist except as provided in other sections of this permit including Section B (relating to Title V General Requirements).

IX. COMPLIANCE SCHEDULE.

No compliance milestones exist.

***** Permit Shield In Effect *****

**SECTION D. Source Level Requirements**

Source ID: 036

Source Name: BOILER SG-B

Source Capacity/Throughput:

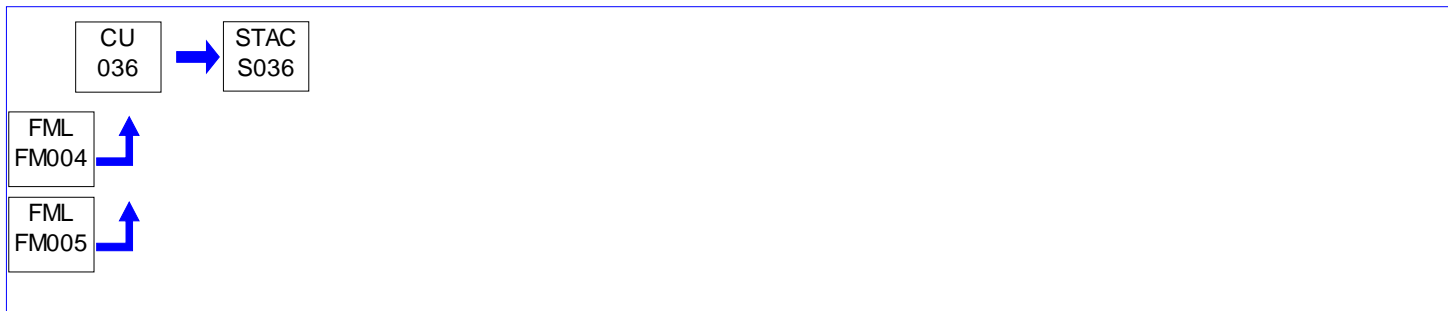
**I. RESTRICTIONS.****Emission Restriction(s).****# 001 [25 Pa. Code §127.441]****Operating permit terms and conditions.**

(a) Additional authority for this permit condition is derived from 25 Pa. Code Sections 127.1, 127.12, 123.11, 123.22 and 40 CFR Part 60 Subpart Db Sections 60.43b and 60.44b. Compliance with the requirements specified in this streamlined permit condition assure compliance with the provisions in 25 Pa Code Sections 123.11 and 123.22 and 40 CFR Part 60 Subpart Db Sections 60.43b and 60.44b. Compliance with the nitrogen oxides limitations specified in this streamlined permit condition ensures compliance with the presumptive RACT provisions specified in 25 Pa. Code Section 129.97(g)(1)(i) and (ii).

Source ID 036 shall never exceed the following emission limits:

Pollutant	lb per MMBTU (natural gas)	lb per MMBTU (#2 fuel oil)
nitrogen oxides (NO _x , expressed as NO ₂)	0.06*	0.10*
carbon monoxide (CO)	0.07*	0.09*
sulfur dioxide (SO ₂)	0.006**	0.5**
volatile organic compounds (VOC)	0.005**	0.005**
particulate matter (PM)	0.013**	0.1**
PM10	0.013**	0.1**

(b) Compliance with the nitrogen oxides limitations specified in this permit condition ensures compliance with the presumptive RACT provisions specified in 25 Pa. Code Section 129.112(g)(1)(i) and (ii):

Pollutant	lb per MMBTU (natural gas)	lb per MMBTU (#2 fuel oil)
nitrogen oxides (NO _x , expressed as NO ₂)	0.10***	0.12***

* 30-day rolling average (which means the average of all hours in each 30 day period in which the respective fuel was burned).

** 3-hour average, as determined by the average of the results of three individual stack test runs.

*** daily average, in accordance with 25 Pa. Code Section 129.115(b)(4)(i) and (ii).

002 [25 Pa. Code §127.441]**Operating permit terms and conditions.**

(a) The combined emissions from Sources ID 036 and 037 shall never exceed the following limitations in any 12 consecutive month period:

Pollutant	tons
-----------	------

**SECTION D. Source Level Requirements**

nitrogen oxides (NO _x , expressed as NO ₂)	79.2
carbon monoxide (CO)	87.5
sulfur dioxide (SO ₂)	98.9
particulate matter (PM)	31.7
PM-10	31.7

(b) Additional authority for this permit condition is derived from 25 Pa. Code Section 129.112(c)(2). The VOC emissions from Source ID 036 shall be less than 2.7 tons per year.

(c) Pounds per MMBTU data generated by the predictive emission monitoring systems for Source ID 036 shall be used to calculate CO and NO_x emissions in pounds per hour and tons per 12 consecutive month period. Reports shall be submitted to the Department's Regional Office on a semiannual basis to verify compliance with the annual CO and NO_x emission limitations.

**# 003 [40 CFR Part 60 Standards of Performance for New Stationary Sources §40 CFR 60.42b]
Subpart Db - Standards of Performance for Industrial- Commercial-Institutional Steam Generating Units
Standard for sulfur dioxide.**

[Additional authority for this permit condition is derived from 25 Pa. Code Sections 127.1, 127.12 and ensures compliance with 123.22(a)(1).]

The permittee shall comply with all applicable standards for sulfur dioxide requirements for Source ID 036 specified in 40 CFR Part 60, Subpart Db, Section 60.42b.

**# 004 [40 CFR Part 60 Standards of Performance for New Stationary Sources §40 CFR 60.43b]
Subpart Db - Standards of Performance for Industrial- Commercial-Institutional Steam Generating Units
Standard for particulate matter.**

The permittee shall comply with all applicable standards for particulate matter requirements for Source ID 036 specified in 40 CFR Part 60, Subpart Db, Section 60.43b.

**# 005 [40 CFR Part 60 Standards of Performance for New Stationary Sources §40 CFR 60.44b]
Subpart Db - Standards of Performance for Industrial- Commercial-Institutional Steam Generating Units
Standard for nitrogen oxides.**

The permittee shall comply with all applicable standards for nitrogen oxides requirements for Source ID 036 specified in 40 CFR Part 60, Subpart Db, Section 60.44b.

Fuel Restriction(s).

**# 006 [25 Pa. Code §127.441]
Operating permit terms and conditions.**

[Additional authority for this permit condition is derived from 40 CFR Sections 63.7499 and 63.7575.]

(a) Source ID 036 shall be fired on #2 fuel oil as follows:

- (i) for the purposes of periodic testing, maintenance, or operator training, not to exceed a combined total of 48 hours during any calendar year; or
- (ii) during periods of gas curtailment or gas supply interruptions of any duration.

(b) Compliance with the fuel restrictions under condition (a) shall qualify Source ID 036 as a "unit designed to burn gas 1 subcategory" as defined in 40 CFR Section 63.7575.

(c) Should the permittee operate Source ID 036 in a manner such that it no longer qualifies as a "unit designed to burn gas 1 subcategory", then the permittee shall comply with all applicable requirements under 40 CFR 63, Subpart DDDDD, as a "unit designed to burn light liquid subcategory".

**# 007 [25 Pa. Code §127.441]
Operating permit terms and conditions.**

[Compliance with this condition ensures compliance with 25 Pa. Code Section 123.22(a)(2)(i).]

**SECTION D. Source Level Requirements**

Source ID 036 shall be fired only on pipeline quality natural gas or #2 fuel oil with a maximum sulfur content of 0.0015% by weight and to which no reclaimed or waste oil or other waste materials have been added.

Throughput Restriction(s).**# 008 [25 Pa. Code §127.441]****Operating permit terms and conditions.**

The combined use of #2 fuel oil in Sources IDs 036 and 037 shall not exceed 2.666667 million gallons in any 12 consecutive month period.

II. TESTING REQUIREMENTS.**# 009 [40 CFR Part 60 Standards of Performance for New Stationary Sources §40 CFR 60.45b]****Subpart Db - Standards of Performance for Industrial- Commercial-Institutional Steam Generating Units
Compliance and performance test methods and procedures for sulfur dioxide.**

The permittee shall comply with all applicable compliance and performance test methods and procedures for sulfur dioxide requirements for Source ID 036 specified in 40 CFR Part 60, Subpart Db, Section 60.45b.

010 [40 CFR Part 60 Standards of Performance for New Stationary Sources §40 CFR 60.46b]**Subpart Db - Standards of Performance for Industrial- Commercial-Institutional Steam Generating Units
Compliance and performance test methods and procedures for particulate matter and nitrogen oxides.**

The permittee shall comply with all applicable compliance and performance test methods and procedures for particulate matter and nitrogen oxides requirements for Source ID 036 specified in 40 CFR Part 60, Subpart Db, Section 60.46b.

III. MONITORING REQUIREMENTS.**# 011 [25 Pa. Code §127.441]****Operating permit terms and conditions.**

(a) In accordance with 40 CFR Part 60 Subpart Db Section 60.48b of the Federal Standards of Performance for New Stationary Sources, the permittee shall maintain and operate a predictive emission monitoring system for nitrogen oxides for Source ID 036. Additionally, in accordance with Section 127.12(a)(3) of 25 Pa. Code Chapter 127, the permittee shall maintain and operate a predictive emission monitoring system for carbon monoxide on Source ID 036. All emission monitoring systems addressed herein shall be maintained and operated in accordance with the requirements specified in Chapter 139 of Article III of the Rules and Regulations of the Department of Environmental Protection and the Department's Continuous Source Monitoring Manual.

(b) In accordance with 40 CFR 60.48b(j)(4), the permittee is exempt from the requirement established in 40 CFR 60.48b to maintain and operate a continuous emission monitoring system for opacity on Source ID 036, provided Source ID 036:

(i) is not equipped with post-combustion technology (except a wet scrubber) for reducing PM, SO₂, or carbon monoxide (CO) emissions;

(ii) burns only gaseous fuels or fuel oils that contain less than or equal to 0.30 weight percent sulfur; and

(iii) is operated such that emissions of CO are maintained at levels less than or equal to 0.15 lb/MMBtu on a steam generating unit operating day average basis.

012 [40 CFR Part 60 Standards of Performance for New Stationary Sources §40 CFR 60.48b]**Subpart Db - Standards of Performance for Industrial- Commercial-Institutional Steam Generating Units
Emission monitoring for particulate matter and nitrogen oxides.**

The permittee shall comply with all applicable emission monitoring for nitrogen oxides for Source ID 036 as specified in 40 CFR Part 60, Subpart Db, Section 60.48b.

IV. RECORDKEEPING REQUIREMENTS.**# 013 [25 Pa. Code §127.441]****Operating permit terms and conditions.**

[Compliance with the provisions pertaining to nitrogen oxides in this streamlined permit condition ensures compliance with

**SECTION D. Source Level Requirements**

25 Pa. Code Sections 129.100(d) and 129.115(f).]

(a) the permittee shall maintain records of the following operating parameters for Source ID 036:

- (1) NOx (expressed as NO₂), CO, SO₂, VOC, total particulate matter, and PM-10 calculations or PEMS emissions results to verify compliance with the annual emission limitations
- (2) Calculations or stack test reports used to verify compliance with the NOx (expressed as NO₂), CO, SO₂, VOC, total particulate matter and PM-10 emissions limitations in lb per MMBTU
- (3) volumes of natural gas and #2 fuel oil combusted in Source ID. 036 on a monthly basis to verify compliance with the fuel usage limitation
- (4) the specific hours during which natural gas is combusted in Source ID. 036 and during which #2 fuel oil is combusted in Source ID. 036 on a monthly basis
- (5) the sulfur % by weight of the #2 oil combusted in Source ID. 036
- (6) continuous emission monitoring system and predictive emission monitoring system emissions data

(b) the permittee shall maintain records to verify that Source ID 036 is being maintained and operated in accordance with the manufacturer's specifications and with good operating practices for the control of the VOC emissions. Additional authority for this condition is derived from 25 Pa. Code Sections 129.100(d) and 129.115(f).

(c) The above records shall be retained for a minimum of five (5) years and shall be made available to the Department upon request.

**# 014 [40 CFR Part 60 Standards of Performance for New Stationary Sources §40 CFR 60.49b]
Subpart Db - Standards of Performance for Industrial- Commercial-Institutional Steam Generating Units
Reporting and recordkeeping requirements.**

The permittee shall comply with all applicable recordkeeping requirements for Source ID 036 specified in 40 CFR Part 60, Subpart Db, Section 60.49b.

V. REPORTING REQUIREMENTS.

015 [25 Pa. Code §127.441]

Operating permit terms and conditions.

(a) The permittee shall submit to the Department on a semiannual basis records of the following operating parameters for Source ID 036:

- (1) records of emissions for NOx (expressed as NO₂), CO, SO₂, VOC, total particulate matter, and PM-10 to verify compliance with the annual emission limitations
- (2) volumes of natural gas and #2 fuel oil combusted in Source ID 036
- (3) the specific hours during which natural gas is combusted in Source ID. 036 and during which #2 fuel oil is combusted in Source ID 036

(b) All semiannual reports shall be submitted to the Department by September 1 for the preceding period January to June and March 1 for the preceding period July to December.

016 [25 Pa. Code §127.441]

Operating permit terms and conditions.

(a) The permittee shall submit the data generated by the emission monitoring systems including pounds per MMBTU data for Source ID. 036 to the Department's Central Office on a quarterly basis in accordance with the Department's Continuous Source Monitoring Manual. The data generated by the emission monitoring systems for Source ID. 036 shall be used to verify compliance with the pounds per MMBTU emission limitations.

(b) Quarterly reports shall be submitted to the Department in accordance with the Department's Continuous Source Monitoring Manual.

(c) The permittee shall use pounds per MMBTU data generated by the predictive emission monitoring systems for Source ID. 036 to calculate CO and NOx emissions in pounds per hour and tons per 12 consecutive month period. Reports shall be submitted to the Department's Regional Office on a semiannual basis to verify compliance with the annual CO and NOx emission limitations. All semiannual reports shall be submitted by September 1 for the preceding period January to June and March 1 for the preceding period July to December.

**SECTION D. Source Level Requirements**

017 [40 CFR Part 60 Standards of Performance for New Stationary Sources §40 CFR 60.49b]
Subpart Db - Standards of Performance for Industrial- Commercial-Institutional Steam Generating Units
Reporting and recordkeeping requirements.

The permittee shall comply with all applicable reporting requirements for Source ID 036 specified in 40 CFR Part 60, Subpart Db, Section 60.49b.

018 [40 CFR Part 60 Standards of Performance for New Stationary Sources §40 CFR 60.49b]
Subpart Db - Standards of Performance for Industrial- Commercial-Institutional Steam Generating Units
Reporting and recordkeeping requirements.

Pursuant to 40 CFR Section 60.4 of the Standards of Performance, the submission of all requests, reports, applications, submittals and other communications required by 40 CFR Part 60 Subpart Db Sections 60.40b - 60.49b must be made to both the Department of Environmental Protection (PADEP) and the Environmental Protection Agency (EPA). The EPA copies may be sent to:

R3_Air_Apps_and_Notices@epa.gov

VI. WORK PRACTICE REQUIREMENTS.

019 [25 Pa. Code §127.441]
Operating permit terms and conditions.

Pursuant to 25 Pa. Code Sections 129.97(d) and 129.112(c), Source ID 036 shall be maintained and operated in accordance with the manufacturer's specifications and with good operating practices for the control of the VOC emissions.

020 [25 Pa. Code §127.441]
Operating permit terms and conditions.

[Additional authority for this permit condition is derived from 25 Pa. Code Sections 127.1 and 127.12.]

Source ID 036 shall be equipped with low NOx burners and flue gas recirculation. Additionally, Source ID 036 shall be operated using good combustion practices.

021 [40 CFR Part 63 NESHAPS for Source Categories §40 CFR 63.7540]
Subpart DDDDD - National Emission Standards for Hazardous Air Pollutants for Major Sources: Industrial, Commercial and Institutional Boilers and Process Heaters.

How do I demonstrate continuous compliance with the emission limitations, fuel specifications and work practice standards?

(a) Pursuant to 40 CFR 63.7540(a)(10), the permittee shall conduct a boiler tune-up which includes the following:

- (1) As applicable, inspect the burner, and clean or replace any components of the burner as necessary (you may perform the burner inspection any time prior to the tune-up or delay the burner inspection until the next scheduled unit shutdown). At units where entry into a piece of process equipment or into a storage vessel is required to complete the tune-up inspections, inspections are required only during planned entries into the storage vessel or process equipment;
- (2) Inspect the flame pattern, as applicable, and adjust the burner as necessary to optimize the flame pattern. The adjustment should be consistent with the manufacturer's specifications, if available;
- (3) Inspect the system controlling the air-to-fuel ratio, as applicable, and ensure that it is correctly calibrated and functioning properly (you may delay the inspection until the next scheduled unit shutdown);
- (4) Optimize total emissions of CO. This optimization should be consistent with the manufacturer's specifications, if available, and with any NOX requirement to which the unit is subject;
- (5) Measure the concentrations in the effluent stream of CO in parts per million, by volume, and oxygen in volume percent, before and after the adjustments are made (measurements may be either on a dry or wet basis, as long as it is the same basis before and after the adjustments are made). Measurements may be taken using a portable CO analyzer; and
- (6) Maintain on-site and submit, if requested by the Administrator, a report containing the following information:

- (i) The concentrations of CO in the effluent stream in parts per million by volume, and oxygen in volume percent, measured at high fire or typical operating load, before and after the tune-up of the boiler;
- (ii) A description of any corrective actions taken as a part of the tune-up; and
- (iii) The type and amount of fuel used over the 12 months prior to the tune-up. Units sharing a fuel meter may estimate the

**SECTION D. Source Level Requirements**

fuel used by each unit.

(b) Pursuant to 40 CFR 63.7540(a)(12), the permittee shall conduct the boiler tune-ups on Source ID 036 every five years. The next such tune-up is due by January 31, 2026.

VII. ADDITIONAL REQUIREMENTS.**# 022 [25 Pa. Code §127.441]****Operating permit terms and conditions.**

Source ID 036 is subject to Subpart DDDDD of the National Emission Standards for Hazardous Air Pollutants for Major Sources: Industrial, Commercial, and Institutional Boilers and Process Heaters, 40 CFR 63.7480 - 63.7575. The permittee shall comply with all applicable requirements of the Subpart.

023 [25 Pa. Code §127.441]**Operating permit terms and conditions.**

Source ID 036 is a Babcox and Wilcox #FM-106-97 natural gas/#2 fuel oil-fired industrial boiler (identified as SG-B), with a nominal rated capacity of 100,000 pounds of steam per hour (138,100,000 BTU per hour).

024 [25 Pa. Code §127.441]**Operating permit terms and conditions.**

Source ID 036 is subject to Subpart Db of the Federal Standards of Performance for New Stationary Sources, 40 CFR Part 60 Sections 60.40b-60.49b. The permittee shall comply with all applicable requirements of this Subpart.

***** Permit Shield in Effect. *****

**SECTION D. Source Level Requirements**

Source ID: 037

Source Name: BOILER SG-C

Source Capacity/Throughput:

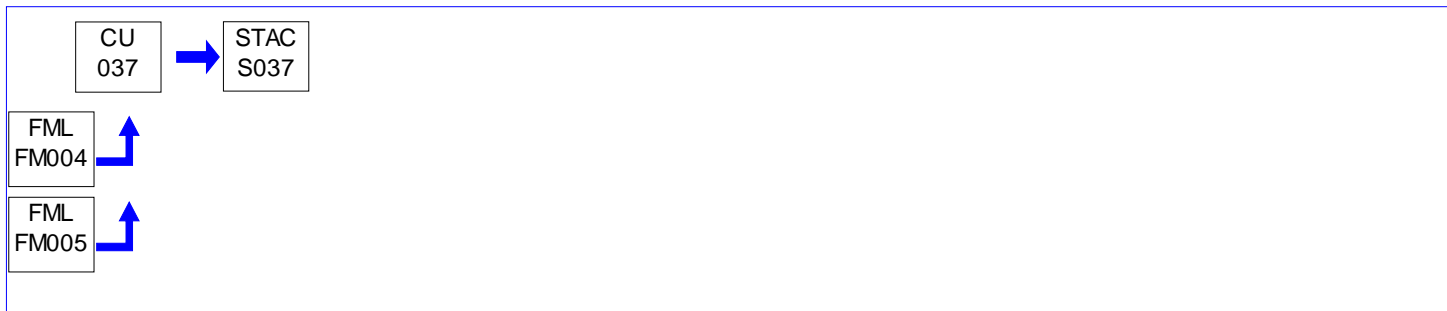
**I. RESTRICTIONS.****Emission Restriction(s).****# 001 [25 Pa. Code §127.441]****Operating permit terms and conditions.**

(a) The combined emissions from Sources ID 036 and 037 shall never exceed the following limitations in any 12 consecutive month period:

Pollutant	tons
nitrogen oxides (NOx, expressed as NO ₂)	79.2
carbon monoxide (CO)	87.5
sulfur dioxide (SO ₂)	98.9
particulate matter (PM)	31.7
PM-10	31.7

(b) Additional authority for this permit condition is derived from 25 Pa. Code Section 129.112(c)(2). The VOC emissions from Source ID 037 shall be less than 2.7 tons per year.

(c) Pounds per MMBTU data generated by the predictive emission monitoring systems for Source ID 037 shall be used to calculate CO and NOx emissions in pounds per hour and tons per 12 consecutive month period. Reports shall be submitted to the Department's Regional Office on a semiannual basis to verify compliance with the annual CO and NOx emission limitations.

002 [25 Pa. Code §127.441]**Operating permit terms and conditions.**

(a) Additional authority for this permit condition is derived from 25 Pa. Code Sections 127.1, 127.12, 123.11, 123.22 and 40 CFR Part 60 Subpart Db Sections 60.43b and 60.44b. Compliance with the requirements specified in this streamlined permit condition assure compliance with the provisions in 25 Pa Code Sections 123.11 and 123.22 and 40 CFR Part 60 Subpart Db Sections 60.43b and 60.44b. Compliance with the nitrogen oxides limitations specified in this streamlined permit condition ensures compliance with the presumptive RACT provisions specified in 25 Pa. Code Section 129.97(g)(1)(i) and (ii).

Source ID 037 shall never exceed the following emission limits:

Pollutant	lb per MMBTU (natural gas)	lb per MMBTU (#2 fuel oil)
nitrogen oxides (NOx, expressed as NO ₂)	0.06*	0.10*
carbon monoxide (CO)	0.07*	0.09*
sulfur dioxide (SO ₂)	0.006**	0.5**
volatile organic compounds (VOC)	0.005**	0.005**
particulate matter (PM)	0.013**	0.1**
PM10	0.013**	0.1**

**SECTION D. Source Level Requirements**

(b) Compliance with the nitrogen oxides limitations specified in this permit condition ensures compliance with the presumptive RACT provisions specified in 25 Pa. Code Section 129.112(g)(1)(i) and (ii):

Pollutant	lb per MMBTU (natural gas)	lb per MMBTU (#2 fuel oil)
nitrogen oxides (NO _x , expressed as NO ₂)	0.10***	0.12***

* 30-day rolling average (which means the average of all hours in each 30 day period in which the respective fuel was burned).

** 3-hour average, as determined by the average of the results of three individual stack test runs.

*** daily average, in accordance with 25 Pa. Code Section 129.115(b)(4)(i) and (ii).

**# 003 [40 CFR Part 60 Standards of Performance for New Stationary Sources §40 CFR 60.42b]
Subpart Db - Standards of Performance for Industrial- Commercial-Institutional Steam Generating Units
Standard for sulfur dioxide.**

[Additional authority for this permit condition is derived from 25 Pa. Code Sections 127.1, 127.12 and ensures compliance with 123.22(a)(1).]

The permittee shall comply with all applicable standards for sulfur dioxide requirements for Source ID 037 specified in 40 CFR Part 60, Subpart Db, Section 60.42b.

**# 004 [40 CFR Part 60 Standards of Performance for New Stationary Sources §40 CFR 60.43b]
Subpart Db - Standards of Performance for Industrial- Commercial-Institutional Steam Generating Units
Standard for particulate matter.**

The permittee shall comply with all applicable standards for particulate matter requirements for Source ID 037 specified in 40 CFR Part 60, Subpart Db, Section 60.43b.

**# 005 [40 CFR Part 60 Standards of Performance for New Stationary Sources §40 CFR 60.44b]
Subpart Db - Standards of Performance for Industrial- Commercial-Institutional Steam Generating Units
Standard for nitrogen oxides.**

The permittee shall comply with all applicable standards for nitrogen oxides requirements for Source ID 037 specified in 40 CFR Part 60, Subpart Db, Section 60.44b.

Fuel Restriction(s).

**# 006 [25 Pa. Code §127.441]
Operating permit terms and conditions.**

[Additional authority for this permit condition is derived from 40 CFR Sections 63.7499 and 63.7575.]

(a) Source ID 037 shall be fired on #2 fuel oil as follows:

- (i) for the purposes of periodic testing, maintenance, or operator training, not to exceed a combined total of 48 hours during any calendar year; or
- (ii) during periods of gas curtailment or gas supply interruptions of any duration.

(b) Compliance with the fuel restrictions under condition (a) shall qualify Source ID 037 as a "unit designed to burn gas 1 subcategory" as defined in 40 CFR Section 63.7575.

(c) Should the permittee operate Source ID 037 in a manner such that it no longer qualifies as a "unit designed to burn gas 1 subcategory", then the permittee shall comply with all applicable requirements under 40 CFR 63, Subpart DDDDD, as a "unit designed to burn light liquid subcategory".

**# 007 [25 Pa. Code §127.441]
Operating permit terms and conditions.**

[Compliance with this condition ensures compliance with 25 Pa. Code Section 123.22(a)(2)(i).]

Source ID 037 shall be fired only on pipeline quality natural gas or #2 fuel oil with a maximum sulfur content of 0.0015% by

**SECTION D. Source Level Requirements**

weight and to which no reclaimed or waste oil or other waste materials have been added.

Throughput Restriction(s).

008 [25 Pa. Code §127.441]

Operating permit terms and conditions.

The combined use of #2 fuel oil in Sources ID 036 and 037 shall not exceed 2.666667 million gallons in any 12 consecutive month period.

II. TESTING REQUIREMENTS.

009 [40 CFR Part 60 Standards of Performance for New Stationary Sources §40 CFR 60.45b]

**Subpart Db - Standards of Performance for Industrial- Commercial-Institutional Steam Generating Units
Compliance and performance test methods and procedures for sulfur dioxide.**

The permittee shall comply with all applicable compliance and performance test methods and procedures for sulfur dioxide requirements for Source ID 037 specified in 40 CFR Part 60, Subpart Db, Section 60.45b.

010 [40 CFR Part 60 Standards of Performance for New Stationary Sources §40 CFR 60.46b]

**Subpart Db - Standards of Performance for Industrial- Commercial-Institutional Steam Generating Units
Compliance and performance test methods and procedures for particulate matter and nitrogen oxides.**

The permittee shall comply with all applicable compliance and performance test methods and procedures for particulate matter and nitrogen oxides requirements for Source ID 037 specified in 40 CFR Part 60, Subpart Db, Section 60.46b.

III. MONITORING REQUIREMENTS.

011 [25 Pa. Code §127.441]

Operating permit terms and conditions.

(a) In accordance with 40 CFR Part 60 Subpart Db Section 60.48b of the Federal Standards of Performance for New Stationary Sources, the permittee shall maintain and operate a predictive emission monitoring system for nitrogen oxides for Source ID 037. Additionally, in accordance with Section 127.12(a)(3) of 25 Pa. Code Chapter 127, the permittee shall maintain and operate a predictive emission monitoring system for carbon monoxide on Source ID 037. All emission monitoring systems addressed herein shall be maintained and operated in accordance with the requirements specified in Chapter 139 of Article III of the Rules and Regulations of the Department of Environmental Protection and the Department's Continuous Source Monitoring Manual.

(b) In accordance with 40 CFR 60.48b(j)(4), the permittee is exempt from the requirement established in 40 CFR 60.48b to maintain and operate a continuous emission monitoring system for opacity on Source ID 037, provided Source ID 037:

(i) is not equipped with post-combustion technology (except a wet scrubber) for reducing PM, SO₂, or carbon monoxide (CO) emissions;

(ii) burns only gaseous fuels or fuel oils that contain less than or equal to 0.30 weight percent sulfur; and

(iii) is operated such that emissions of CO are maintained at levels less than or equal to 0.15 lb/MMBtu on a steam generating unit operating day average basis.

012 [40 CFR Part 60 Standards of Performance for New Stationary Sources §40 CFR 60.48b]

**Subpart Db - Standards of Performance for Industrial- Commercial-Institutional Steam Generating Units
Emission monitoring for particulate matter and nitrogen oxides.**

The permittee shall comply with all applicable emission monitoring for nitrogen oxides for Source ID 037 as specified in 40 CFR Part 60, Subpart Db, Section 60.48b.

IV. RECORDKEEPING REQUIREMENTS.

013 [25 Pa. Code §127.441]

Operating permit terms and conditions.

[Compliance with the provisions pertaining to nitrogen oxides in this streamlined permit condition ensures compliance with

**SECTION D. Source Level Requirements**

25 Pa. Code Sections 129.100(d) and 129.115(f).]

(a) the permittee shall maintain records of the following operating parameters for Source ID 037:

- (1) NOx (expressed as NO₂), CO, SO₂, VOC, total particulate matter, and PM-10 calculations or PEMS emissions results to verify compliance with the annual emission limitations
- (2) Calculations or stack test reports used to verify compliance with the NOx (expressed as NO₂), CO, SO₂, VOC, total particulate matter and PM-10 emissions limitations in lb per MMBTU
- (3) volumes of natural gas and #2 fuel oil combusted in Source ID. 037 on a monthly basis to verify compliance with the fuel usage limitation
- (4) the specific hours during which natural gas is combusted in Source ID. 037 and during which #2 fuel oil is combusted in Source ID. 037 on a monthly basis
- (5) test reports or fuel analysis reports to verify the sulfur % by weight of the #2 oil combusted in Source ID. 037
- (6) continuous emission monitoring system and predictive emission monitoring system emissions data

(b) The permittee shall maintain records to verify that Source ID 037 is being maintained and operated in accordance with the manufacturer's specifications and with good operating practices for the control of the VOC emissions. Additional authority for this condition is derived from 25 Pa. Code Sections 129.100(d) and 129.115(f).

(c) The above records shall be retained for a minimum of five (5) years and shall be made available to the Department upon request.

**# 014 [40 CFR Part 60 Standards of Performance for New Stationary Sources §40 CFR 60.49b]
Subpart Db - Standards of Performance for Industrial- Commercial-Institutional Steam Generating Units
Reporting and recordkeeping requirements.**

The permittee shall comply with all applicable recordkeeping requirements for Source ID 037 specified in 40 CFR Part 60, Subpart Db, Section 60.49b.

V. REPORTING REQUIREMENTS.

015 [25 Pa. Code §127.441]

Operating permit terms and conditions.

(a) The permittee shall submit the data generated by the emission monitoring systems including pounds per MMBTU data for Source ID 037 to the Department's Central Office on a quarterly basis in accordance with the Department's Continuous Source Monitoring Manual. The data generated by the emission monitoring systems for Source ID 037 shall be used to verify compliance with the pounds per MMBTU emission limitations.

(b) Quarterly reports shall be submitted to the Department in accordance with the Department's Continuous Source Monitoring Manual.

(c) The permittee shall use pounds per MMBTU data generated by the predictive emission monitoring systems for Source ID 037 to calculate CO and NOx emissions in pounds per hour and tons per 12 consecutive month period. Reports shall be submitted to the Department's Regional Office on a semiannual basis to verify compliance with the annual CO and NOx emission limitations. All semiannual reports shall be submitted by September 1 for the preceding period January to June and March 1 for the preceding period July to December.

016 [25 Pa. Code §127.441]

Operating permit terms and conditions.

(a) The permittee shall submit to the Department on a semiannual basis records of the following operating parameters for Source ID 037:

- (1) records of emissions for NOx (expressed as NO₂), CO, SO₂, VOC, total particulate matter, and PM-10 to verify compliance with the annual emission limitations
- (2) volumes of natural gas and #2 fuel oil combusted in Source ID 037
- (3) the specific hours during which natural gas is combusted in Source ID. 037 and during which #2 fuel oil is combusted in Source ID 037

(b) All semiannual reports shall be submitted to the Department by September 1 for the preceding period January to June and March 1 for the preceding period July to December.

**SECTION D. Source Level Requirements**

017 [40 CFR Part 60 Standards of Performance for New Stationary Sources §40 CFR 60.49b]
Subpart Db - Standards of Performance for Industrial- Commercial-Institutional Steam Generating Units
Reporting and recordkeeping requirements.

The permittee shall comply with all applicable reporting requirements for Source ID 037 specified in 40 CFR Part 60, Subpart Db, Section 60.49b.

018 [40 CFR Part 60 Standards of Performance for New Stationary Sources §40 CFR 60.49b]
Subpart Db - Standards of Performance for Industrial- Commercial-Institutional Steam Generating Units
Reporting and recordkeeping requirements.

Pursuant to 40 CFR Section 60.4 of the Standards of Performance, the submission of all requests, reports, applications, submittals and other communications required by 40 CFR Part 60 Subpart Db Sections 60.40b - 60.49b must be made to both the Department of Environmental Protection (PADEP) and the Environmental Protection Agency (EPA). The EPA copies may be sent to:

R3_Air_Apps_and_Notices@epa.gov

VI. WORK PRACTICE REQUIREMENTS.

019 [25 Pa. Code §127.441]
Operating permit terms and conditions.

Pursuant to 25 Pa. Code Sections 129.97(d) and 129.112(c), Source ID 037 shall be maintained and operated in accordance with the manufacturer's specifications and with good operating practices for the control of the VOC emissions.

020 [25 Pa. Code §127.441]
Operating permit terms and conditions.

[Additional authority for this permit condition is derived from 25 Pa. Code Sections 127.1 and 127.12.]

Source ID 037 shall be equipped with low NOx burners and flue gas recirculation. Additionally, Source ID 037 shall be operated using good combustion practices.

021 [40 CFR Part 63 NESHAPS for Source Categories §40 CFR 63.7540]
Subpart DDDDD - National Emission Standards for Hazardous Air Pollutants for Major Sources: Industrial, Commercial and Institutional Boilers and Process Heaters.
How do I demonstrate continuous compliance with the emission limitations, fuel specifications and work practice standards?

(a) Pursuant to 40 CFR 63.7540(a)(10), the permittee shall conduct a boiler tune-up which includes the following:

- (1) As applicable, inspect the burner, and clean or replace any components of the burner as necessary (you may perform the burner inspection any time prior to the tune-up or delay the burner inspection until the next scheduled unit shutdown). At units where entry into a piece of process equipment or into a storage vessel is required to complete the tune-up inspections, inspections are required only during planned entries into the storage vessel or process equipment;
- (2) Inspect the flame pattern, as applicable, and adjust the burner as necessary to optimize the flame pattern. The adjustment should be consistent with the manufacturer's specifications, if available;
- (3) Inspect the system controlling the air-to-fuel ratio, as applicable, and ensure that it is correctly calibrated and functioning properly (you may delay the inspection until the next scheduled unit shutdown);
- (4) Optimize total emissions of CO. This optimization should be consistent with the manufacturer's specifications, if available, and with any NOX requirement to which the unit is subject;
- (5) Measure the concentrations in the effluent stream of CO in parts per million, by volume, and oxygen in volume percent, before and after the adjustments are made (measurements may be either on a dry or wet basis, as long as it is the same basis before and after the adjustments are made). Measurements may be taken using a portable CO analyzer; and
- (6) Maintain on-site and submit, if requested by the Administrator, a report containing the following information:

- (i) The concentrations of CO in the effluent stream in parts per million by volume, and oxygen in volume percent, measured at high fire or typical operating load, before and after the tune-up of the boiler;
- (ii) A description of any corrective actions taken as a part of the tune-up; and
- (iii) The type and amount of fuel used over the 12 months prior to the tune-up. Units sharing a fuel meter may estimate the

**SECTION D. Source Level Requirements**

fuel used by each unit.

(b) Pursuant to 40 CFR 63.7540(a)(12), the permittee shall conduct the boiler tune-ups on Source ID 037 every five years. The next such tune-up is due by January 31, 2026.

VII. ADDITIONAL REQUIREMENTS.**# 022 [25 Pa. Code §127.441]****Operating permit terms and conditions.**

Source ID 037 is subject to Subpart Db of the Federal Standards of Performance for New Stationary Sources, 40 CFR Part 60 Sections 60.40b-60.49b. The permittee shall comply with all applicable requirements of this Subpart.

023 [25 Pa. Code §127.441]**Operating permit terms and conditions.**

Source ID 037 is subject to Subpart DDDDD of the National Emission Standards for Hazardous Air Pollutants for Major Sources: Industrial, Commercial, and Institutional Boilers and Process Heaters, 40 CFR 63.7480 - 63.7575. The permittee shall comply with all applicable requirements of the Subpart.

024 [25 Pa. Code §127.441]**Operating permit terms and conditions.**

Source ID 037 is a Babcox and Wilcox #FM-106-97 natural gas/#2 fuel oil-fired industrial boiler (identified as SG-C), with a nominal rated capacity of 100,000 pounds of steam per hour (138,100,000 BTU per hour).

***** Permit Shield in Effect. *****

**SECTION D. Source Level Requirements**

Source ID: 101

Source Name: WASTEWATER TREATMENT PLANT

Source Capacity/Throughput:

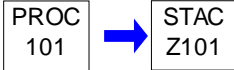
**I. RESTRICTIONS.****Emission Restriction(s).****# 001 [25 Pa. Code §127.441]****Operating permit terms and conditions.**

[Additional authority for this condition is derived from 25 Pa. Code Sections 129.99(d) and 129.114(i)(1)(i).]

Pursuant to the best available technology provisions in 25 Pa. Code Sections 127.1 and 127.12, the VOC emissions from Source ID 101 shall not exceed 15 tons in any 12 consecutive month period.

II. TESTING REQUIREMENTS.

No additional testing requirements exist except as provided in other sections of this permit including Section B (Title V General Requirements).

III. MONITORING REQUIREMENTS.**# 002 [25 Pa. Code §127.441]****Operating permit terms and conditions.**

[Additional authority for this permit condition is derived from 25 Pa. Code Section 127.511 and 40 CFR Part 63, Subpart GGG]

The permittee shall monitor and record the mixed liquor suspended solids (MLSS) in each aeration basin once each day, and shall monitor and record the temperature in Source ID 101 once each day using a continuous in-line device. The permittee shall meet the minimum MLSS concentration as outlined in the site's Notification of Compliance Status Reports.

003 [25 Pa. Code §127.441]**Operating permit terms and conditions.**

[Additional authority for this permit condition is derived from 25 Pa. Code Section 127.511 and 40 CFR Part 63, Subpart GGG]

The influent solvent load to Source ID 101 shall be measured and recorded daily by conducting a GC analysis on the daily composite influent sample.

IV. RECORDKEEPING REQUIREMENTS.**# 004 [25 Pa. Code §127.441]****Operating permit terms and conditions.**

The daily records of the MLSS measurements, temperature measurements and calculated minimum MLSS limits at a given temperature shall be retained for a minimum of 5 years and shall be made available to the Department upon request.

005 [25 Pa. Code §127.441]**Operating permit terms and conditions.**

The daily records of the GC analysis results of the daily composite influent sample shall be retained for a minimum of 5 years and shall be made available to the Department upon request.

006 [25 Pa. Code §127.441]**Operating permit terms and conditions.**

[Additional authority for this permit condition is derived from 25 Pa. Code Sections 129.100(d) and 129.115(f).]

**SECTION D. Source Level Requirements**

- (a) The permittee shall keep records each month of the supporting calculations to verify compliance with the VOC emission limitation in any 12 consecutive month period for Source ID 101. These records shall include a description of the methods used to determine this data (emission modeling methods, emission factors, emissions data, calculations, etc. as well as all assumptions made for all emission estimates calculated).
- (b) The permittee shall maintain records to ensure all volatile organic compound-emitting sources under Source 101 are being operated in accordance with good operating practices.
- (c) These records shall be made available to the Department upon request and shall remain on file for a minimum of five years.

V. REPORTING REQUIREMENTS.**# 007 [25 Pa. Code §127.441]****Operating permit terms and conditions.**

[Additional authority for this permit condition is derived from 25 Pa. Code Sections 127.442 and 129.115(f).]

The permittee shall submit to the Department on a semiannual basis records of VOC emission calculations verifying compliance with the 12 consecutive month VOC emission limitation for Source ID 101.

The semiannual reports shall be submitted to the Department no later than March 1 (for January through December of the previous year) and September 1 (for July of the previous year through June of the current year).

008 [25 Pa. Code §127.441]**Operating permit terms and conditions.**

(a) The permittee shall submit semiannual reports as specified in 40 CFR Section 63.1260(g)(2). The permittee shall also comply with the reporting requirements as specified in 40 CFR Section 63.1260(i).

(b) The semiannual reports shall be submitted to the Department no later than September 1 (for January through June) and March 1 (for July through December of the previous year).

009 [25 Pa. Code §127.441]**Operating permit terms and conditions.**

The permittee shall submit Notification of Process Change reports as specified in 40 CFR Section 63.1260(h).

VI. WORK PRACTICE REQUIREMENTS.**# 010 [25 Pa. Code §127.441]****Operating permit terms and conditions.**

[Additional authority for this permit condition is derived from 25 Pa. Code Sections 129.99(d) and 129.114(i)(1)(i).]

All wastewater treatment equipment of Source ID 101 shall be operated so as to maximize the biodegradation of all dissolved volatiles contained in the wastewater.

011 [25 Pa. Code §127.441]**Operating permit terms and conditions.**

Pursuant to 25 Pa. Code Sections 129.99(d) and 129.114(i)(1)(i), the permittee shall maintain good operating practices of all volatile organic compound-emitting sources under Source ID 101.

VII. ADDITIONAL REQUIREMENTS.**# 012 [25 Pa. Code §127.441]****Operating permit terms and conditions.**

Source ID 101 is a wastewater treatment plant that treats permitted wastewater streams from on-site processes as approved by the Department. Source ID 101 includes the following operations:

- (1) Influent wet well (TA-100)
- (2) Back up influent wet well (MH-18)
- (3) Equalization basin (TA-110)
- (4) Neutralization basin (TA-120)

**SECTION D. Source Level Requirements**

- (5) Primary lift station (TA-140)
- (6) Heat exchangers (HE-140A, HE-140B and HE-140C)
- (7) Distribution tank (TA-160)
- (8) Aeration basins (TA-180, TA-181)
- (9) Aeration basins (TA-183W, TA-183C and TA-183E)
- (10) Three 440,000 gallon aeration tanks (TA-184W, TA-184C, TA-184E)
- (11) Aerobic digester (TA-182)
- (12) Flocculation tank (TA-196)
- (13) Secondary clarifiers (CF-190, CF-191 and CF-192)
- (14) Lift station (TA-601)
- (15) Chlorine contact tanks (TA-600A and TA-600B)
- (16) One sulfur dioxide de-chlorination system

013 [25 Pa. Code §127.441]**Operating permit terms and conditions.**

[Additional authority for this permit condition is derived from 40 CFR Sections 63.1250 and 63.1256]

Source ID 101 is subject to the wastewater provisions of 40 CFR Part 63, Subpart GGG. The permittee shall comply with all applicable requirements of 40 CFR Part 63 Section 63.1256. In addition, the permittee shall comply with the wastewater standards and associated work practice standards, monitoring, recordkeeping and reporting requirements identified in the site's Notification of Compliance Status Reports.

014 [25 Pa. Code §127.441]**Operating permit terms and conditions.**

[Additional authority for this condition is derived from 25 Pa. Code Sections 129.99(d) and 129.114(i)(1)(i).]

Pursuant to 40 CFR Section 63.1256(b), the air contaminant emissions from the following wastewater tanks of Source ID 101 shall be controlled by the installation of covers:

- (1) influent wet well (TA-100)
- (2) equalization basin (TA-110)
- (3) neutralization basin (TA-120)
- (4) primary lift station (TA-140)

015 [25 Pa. Code §127.441]**Operating permit terms and conditions.**

The permittee shall reduce the mass of HAPs in Source ID 101 in accordance with 40 CFR Section 63.1256(g).

***** Permit Shield in Effect. *****

**SECTION D. Source Level Requirements**

Source ID: 102

Source Name: SLUDGE DRYING OPERATIONS

Source Capacity/Throughput:

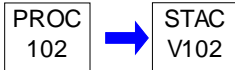
**I. RESTRICTIONS.****Emission Restriction(s).****# 001 [25 Pa. Code §123.13]****Processes**

No person may permit the emission into the outdoor atmosphere of particulate matter from Source ID 102 in a manner that the concentration of particulate matter in the effluent gas exceeds 0.04 grain per dry standard cubic foot.

002 [25 Pa. Code §127.441]**Operating permit terms and conditions.**

Pursuant to the best available technology provisions in 25 Pa. Code Sections 127.1 and 127.12, the total combined VOC emissions from the wastewater treatment sludge dryer of Source ID 102 (Komline-Sanderson Paddle Dryer Model 13W-2000) shall not exceed 0.5 tons in any 12 consecutive month period.

003 [25 Pa. Code §127.441]**Operating permit terms and conditions.**

The wastewater treatment sludge dryer exhaust of Source ID 102 shall be discharged to any one of the following aeration basins of Source ID 101: TA-183W, TA-183C, TA-183E, TA-184W, TA-184C, TA-184E, TA-180, TA-181 or TA-182 via the basins' air diffusers to allow for the biodegradation of the volatile organic compounds contained within the dryer exhaust.

II. TESTING REQUIREMENTS.

No additional testing requirements exist except as provided in other sections of this permit including Section B (Title V General Requirements).

III. MONITORING REQUIREMENTS.

No additional monitoring requirements exist except as provided in other sections of this permit including Section B (Title V General Requirements).

IV. RECORDKEEPING REQUIREMENTS.**# 004 [25 Pa. Code §127.441]****Operating permit terms and conditions.**

The permittee shall keep records of the supporting VOC emission calculations each month to verify compliance with the VOC emission limitation in any 12 consecutive month period for Source ID 102.

These records shall be retained on file for a minimum of five (5) years and made available to the Department upon request.

V. REPORTING REQUIREMENTS.**# 005 [25 Pa. Code §127.441]****Operating permit terms and conditions.**

[Additional authority for this permit condition is derived from 25 Pa. Code Section 127.442]

The permittee shall submit to the Department on a semiannual basis the records of the VOC emission calculations verifying compliance with the 12 consecutive month VOC emission limitation for Source ID 102.

The semiannual reports shall be submitted to the Department no later than March 1 (for January through December of the

**SECTION D. Source Level Requirements**

previous year) and September 1 (for July of the previous year through June of the current year).

VI. WORK PRACTICE REQUIREMENTS.

No additional work practice requirements exist except as provided in other sections of this permit including Section B (Title V General Requirements).

VII. ADDITIONAL REQUIREMENTS.

006 [25 Pa. Code §127.441]

Operating permit terms and conditions.

Source ID 102 is a sludge drying and conveying system associated with the subject facility's wastewater treatment plant (Source ID 101). Source ID 102 consists of the following operations:

- (1) Komline-Sanderson Paddle Dryer Model 13W-2000 wastewater treatment sludge dryer (DR-530) utilizing indirect steam heat
- (2) venturi scrubber SC-557
- (3) seal tank TA-557A
- (4) condenser CN-557A
- (5) condenser CN-557B
- (6) heat exchanger HE-557
- (7) TA-181W (solids from CF-130 and CF-131 of Source ID. 101)
- (8) wet sludge handling system consisting of:
 - (i) mix tank TA-195
 - (ii) rotary screen thickeners RS-500A and RS-500B
 - (iii) holding tank TA-500
 - (iv) filter presses BFP-505N and BFP-505S
 - (v) wet sludge hoppers HP-340 and HP-350

***** Permit Shield in Effect. *****

**SECTION D. Source Level Requirements**

Source ID: 131

Source Name: 300 PAD WASTEWATER SYSTEM

Source Capacity/Throughput:

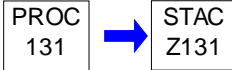
**I. RESTRICTIONS.****Emission Restriction(s).****# 001 [25 Pa. Code §127.441]****Operating permit terms and conditions.**

Pursuant to 25 Pa. Code Sections 129.97(c)(2) and 129.112(c)(2), the total combined volatile organic compound emissions from tanks TA-870, TA-886, TA-887, TA-888, TA-774, TA-775, TA-757, TA-342, and TA-340 shall be less than 2.7 tons per year.

002 [25 Pa. Code §127.441]**Operating permit terms and conditions.**

[Additional authority for this permit condition is derived from 40 CFR 63.1255.]

The permittee shall comply with all applicable standards for equipment leaks specified in 40 CFR Part 63 Subpart GGG, Section 63.1255 for Source ID 131.

003 [25 Pa. Code §127.441]**Operating permit terms and conditions.**

[Additional authority for this permit condition is derived from 40 CFR 63.1252.]

The permittee shall comply with all applicable emission standards specified in 40 CFR Part 63 Subpart GGG, Section 63.1252 for Source ID 131.

II. TESTING REQUIREMENTS.**# 004 [25 Pa. Code §127.441]****Operating permit terms and conditions.**

[Additional authority for this permit condition is derived from 40 CFR 63.1257.]

The permittee shall comply with all applicable test methods and compliance procedures specified in 40 CFR Part 63 Subpart GGG, Section 63.1257 for Source ID 131.

III. MONITORING REQUIREMENTS.**# 005 [25 Pa. Code §127.441]****Operating permit terms and conditions.**

[Additional authority for this permit condition is derived from 40 CFR 63.1258.]

The permittee shall comply with all applicable monitoring and inspection requirements specified in 40 CFR Part 63 Subpart GGG, Section 63.1258 for Source ID 131.

IV. RECORDKEEPING REQUIREMENTS.**# 006 [25 Pa. Code §127.441]****Operating permit terms and conditions.**

[Additional authority for this permit condition is derived from 25 Pa. Code Section 129.115(f).]

The permittee shall keep records of supporting calculations used to verify compliance with the 12 consecutive month VOC emission limitation for the tanks of Source ID 131. All such records shall be made available to the Department upon request and shall remain on file for a minimum of five (5) years.

**SECTION D. Source Level Requirements****# 007 [25 Pa. Code §127.441]****Operating permit terms and conditions.**

[Additional authority for this permit condition is derived from 40 CFR 63.1259.]

The permittee shall comply with all applicable recordkeeping requirements specified in 40 CFR Part 63 Subpart GGG, Section 63.1259 for Source ID 131.

V. REPORTING REQUIREMENTS.**# 008 [25 Pa. Code §127.441]****Operating permit terms and conditions.**

[Additional authority for this permit condition is derived from 40 CFR 63.1260.]

The permittee shall comply with all applicable reporting requirements as specified in 40 CFR Part 63 Subpart GGG, Section 63.1260 for Source ID 131. All reports shall be submitted to the Department and the EPA.

VI. WORK PRACTICE REQUIREMENTS.**# 009 [25 Pa. Code §127.441]****Operating permit terms and conditions.**

[Additional authority for this permit condition is derived from 25 Pa. Code Section 129.112(c).]

The permittee shall install, maintain and operate the sources identified under Source ID 131 in accordance with the manufacturer's specifications and with good operating practices.

VII. ADDITIONAL REQUIREMENTS.**# 010 [25 Pa. Code §127.441]****Operating permit terms and conditions.**

Source ID 131 is a wastewater system associated with the aqueous and organic wastes generated by the pharmaceutical/chemical processes of Source ID 140. Source ID 131 is known as the "300 Pad Wastewater System" and includes the following vessels and equipment:

TA-870	TA-757	TA-774
TA-886	TA-342	TA-775
TA-887	HE-351	TA-780
TA-888	HE-357	RE-355
TA-340	RE-350	

011 [25 Pa. Code §127.441]**Operating permit terms and conditions.**

[Additional authority for this permit condition is derived from 40 CFR Part 63, Subpart GGG, Sections 63.1250 - 63.1260]

Source ID 131 is subject to Subpart GGG of the National Emission Standards for Hazardous Air Pollutants for Source Categories, Pharmaceuticals Production, 40 CFR Part 63 Sections 63.1250 - 63.1260. The permittee shall comply with all applicable requirements of this Subpart of the National Emission Standards for Hazardous Air Pollutants for Source Categories for Source ID 131.

012 [25 Pa. Code §127.441]**Operating permit terms and conditions.**

[Additional authority for this permit condition is derived from 40 CFR 63.1250.]

The permittee shall comply with all applicable requirements specified in Table 1 to 40 CFR 63, Subpart GGG, "General Provisions Applicability to Subpart GGG" for Source ID 131.

**SECTION D. Source Level Requirements****# 013 [25 Pa. Code §127.441]****Operating permit terms and conditions.**

[Additional authority for this permit condition is also derived from 25 Pa. Code Sections 129.91 - 129.95, 127.1 and 127.12. Compliance with this streamlined condition ensures compliance with 25 Pa. Code Sections 129.111-129.115.]

Tanks TA-870, TA-886, TA-887 and TA-888 shall each be equipped with submerged tank fill lines, sealed overflow lines, and small diameter manway vents.

***** Permit Shield in Effect. *****

**SECTION D. Source Level Requirements**

Source ID: 135

Source Name: ERC AWARDED SOURCES

Source Capacity/Throughput:

I. RESTRICTIONS.**Operation Hours Restriction(s).****# 001 [25 Pa. Code §127.441]****Operating permit terms and conditions.**

The permittee shall not operate the Multiple Hearth Sludge Incinerator (formerly Source ID 001) of Source ID 135 unless a plan approval is obtained from the Department. The plan approval application must evaluate the Multiple Hearth Sludge Incinerator as a new source.

II. TESTING REQUIREMENTS.

No additional testing requirements exist except as provided in other sections of this permit including Section B (Title V General Requirements).

III. MONITORING REQUIREMENTS.

No additional monitoring requirements exist except as provided in other sections of this permit including Section B (Title V General Requirements).

IV. RECORDKEEPING REQUIREMENTS.

No additional record keeping requirements exist except as provided in other sections of this permit including Section B (Title V General Requirements).

V. REPORTING REQUIREMENTS.

No additional reporting requirements exist except as provided in other sections of this permit including Section B (Title V General Requirements).

VI. WORK PRACTICE REQUIREMENTS.

No additional work practice requirements exist except as provided in other sections of this permit including Section B (Title V General Requirements).

VII. ADDITIONAL REQUIREMENTS.**# 002 [25 Pa. Code §127.441]****Operating permit terms and conditions.**

Source ID 135 consists of shut down BSP #2 fuel oil/natural gas fired multiple hearth sludge incinerator (formerly Source ID 001) having a primary burner capacity of 6.6 MMBtu/hr.

***** Permit Shield in Effect. *****

**SECTION D. Source Level Requirements**

Source ID: 140

Source Name: PHARMACEUTICAL/CHEMICAL MANUFACTURING

Source Capacity/Throughput:

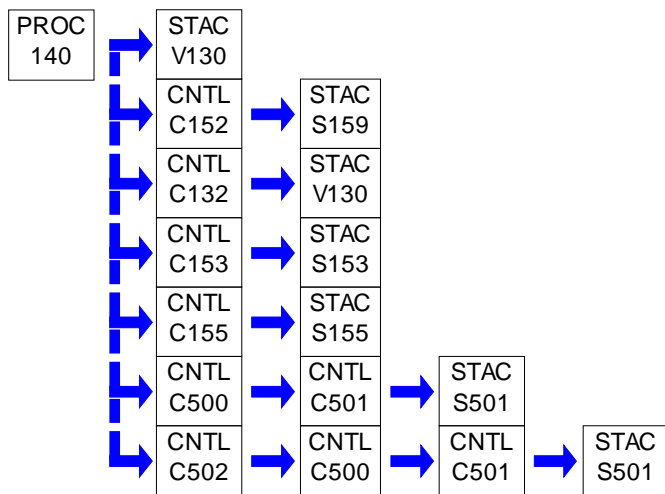
**I. RESTRICTIONS.****Emission Restriction(s).****# 001 [25 Pa. Code §127.441]****Operating permit terms and conditions.**

Pursuant to the best available technology provisions of 25 Pa. Code Sections 127.1 and 127.12, during thermal oxidizer (Control Device ID C500) or associated scrubber (Control Device ID C501) malfunctions or during annual planned TOU and/or associated scrubber maintenance, the following type of processes may operate without TOU and associated scrubber control (i.e., not subject to new batch charge stoppage and stable hold point alternative operating scenario):

(a) A process that emits less than 1.0 ton of VOCs in any 12 consecutive month period (from the sum of all process vents within a process) and emits HAPs less than the amount specified in 40 CFR Section 63.1254(a)(2)(i) (900 kg in any 365-day period).

(b) The sum of all process vent emissions from all processes that comply with (a) above shall be less than 2.0 tons of VOCs in any 12 consecutive month period and 1,800 kg of HAPs in any 365-day period as specified in 40 CFR Section 63.1254(a)(2)(ii).

002 [25 Pa. Code §127.441]**Operating permit terms and conditions.**

Pursuant to 25 Pa. Code Section 123.13(c)(1)(i), no person may permit the emission from the exhaust of Control Device IDs C153, C155 or any scrubber of Control Device ID C152 associated with Source ID 140 into the outdoor atmosphere of particulate matter in excess of 0.04 grains per dry standard cubic foot.

003 [25 Pa. Code §127.441]**Operating permit terms and conditions.**

Pursuant to the best available technology provisions of 25 Pa. Code Sections 127.1 and 127.12, all point source volatile organic compound (VOC) emissions from Source ID 140 shall not exceed a total of 12.0 tons in any 12 consecutive month period.

004 [25 Pa. Code §127.441]**Operating permit terms and conditions.**

Pursuant to the best available technology provisions of 25 Pa. Code Sections 127.1 and 127.12, all point source hazardous air pollutant (HAP) emissions from Source ID 140 shall not exceed a total of 6.0 tons in any 12 consecutive month period.

**SECTION D. Source Level Requirements****Throughput Restriction(s).****# 005 [25 Pa. Code §127.441]****Operating permit terms and conditions.**

The use of any hazardous air pollutants other than those identified in any plan approval application (toluene, hexane, triethylamine, acetonitrile, methylene chloride, trimethyl pentane, dimethyl formamide, HCl and methanol) is prohibited unless the permittee has first requested permission, in writing, and has subsequently received Department approval to do so.

Control Device Efficiency Restriction(s).**# 006 [25 Pa. Code §127.441]****Operating permit terms and conditions.**

Pursuant to the best available technology provisions of 25 Pa. Code Sections 127.1 and 127.12, the combination venturi jet/packed bed caustic scrubber (CL-1053) (Control Device ID C502) used to control the air contaminant emissions from RE-1022 of Source ID 140 shall provide a minimum 99% hydrogen chloride removal efficiency.

007 [25 Pa. Code §127.441]**Operating permit terms and conditions.**

Pursuant to the best available technology provisions of 25 Pa. Code Sections 127.1 and 127.12, packed bed scrubber CL-1673 (Control Device ID C155) shall maintain a VOC removal efficiency of at least 98 percent.

II. TESTING REQUIREMENTS.

No additional testing requirements exist except as provided in other sections of this permit including Section B (Title V General Requirements).

III. MONITORING REQUIREMENTS.**# 008 [25 Pa. Code §127.441]****Operating permit terms and conditions.**

Pursuant to the best available technology provisions of 25 Pa. Code Sections 127.1 and 127.12, the combination venturi jet/packed bed caustic scrubber (CL-1053) (Control Device ID C502) shall be equipped with monitors or gauges that will accurately monitor the scrubbing solution pH and flow rates.

009 [25 Pa. Code §127.441]**Operating permit terms and conditions.**

The condensers identified in Source ID 140 shall each be equipped with temperature gauges that accurately measure the condenser inlet coolant temperature.

010 [25 Pa. Code §127.441]**Operating permit terms and conditions.**

The packed bed scrubber CL-1673 (Control Device ID C155) shall be equipped with monitors or gauges that accurately monitor the scrubber water and make up water flow rates.

011 [25 Pa. Code §127.441]**Operating permit terms and conditions.**

The packed bed scrubber CL-3520 (Control Device ID C153) shall be equipped with monitors that will accurately monitor the scrubbing solution flow rate and pH and the pressure drop across the scrubber.

012 [25 Pa. Code §127.441]**Operating permit terms and conditions.**

Pursuant to the best available technology provisions of 25 Pa. Code Sections 127.1 and 127.12, fugitive VOC and acetone emissions from equipment leaks from the Source ID 140 equipment shall be controlled by conducting weekly inspections of process equipment, during operation, for visible, audible or olfactory indications of leaks. Records of each inspection shall be maintained for a minimum of five years and shall include the results of each inspection and when leaky components have been repaired or replaced. Leaky components shall be repaired or replaced as soon as practicable, but not later than 15 calendar days after it is detected. Delay of repair for VOC and acetone equipment leaks is allowed if the permittee

**SECTION D. Source Level Requirements**

complies with the repair requirements of 40 CFR Part 63 Subpart GGG Section 63.1255(b)(4)(i).

013 [25 Pa. Code §127.441]**Operating permit terms and conditions.**

Pursuant to the best available technology provisions of 25 Pa. Code Sections 127.1 and 127.12, fugitive HAP emissions shall be controlled by compliance with the leak detection and repair (LDAR) provisions of 40 CFR Section 63.1255.

IV. RECORDKEEPING REQUIREMENTS.**# 014 [25 Pa. Code §127.441]****Operating permit terms and conditions.**

During INS (Imipenem Non-Sterile) processing, or any other time TA-1031 contains methylene chloride, the permittee shall inspect the pressure relief valve of TA-1031, if used during thermal oxidizer or associated scrubber malfunction, and shall record whether or not the pressure relief valve released pressure during malfunction to verify that no point source methylene chloride emissions were vented to the atmosphere. These records shall be retained for a minimum of five years and shall be made available to the Department upon request.

015 [25 Pa. Code §127.441]**Operating permit terms and conditions.**

The permittee shall keep records of the stable hold points of each process of Source ID 140. The list of stable hold points shall be kept up to date and shall be made available to the Department upon request.

016 [25 Pa. Code §127.441]**Operating permit terms and conditions.**

The permittee shall keep records of those processes that continue to operate (i.e., not subject to new batch charge stoppage and stable hold point alternative operating scenario) during thermal oxidizer (Control Device ID C500) or associated scrubber (Control Device ID C501) malfunctions or during annual planned TOU and/or associated scrubber maintenance to verify that each process emits less than 1.0 ton of VOCs in any 12 consecutive month period (from the sum of all process vents within a process) and emits HAPs less than the amount specified in 40 CFR Section 63.1254(a)(2)(i) (900 kg in any 365-day period) and to verify that the sum of all process vent emissions from all processes are less than 2.0 tons of VOCs in any 12 consecutive month period and 1,800 kg of HAPs in any 365-day period as specified in 40 CFR Section 63.1254(a)(2)(ii).

These records shall be retained for a minimum of five years and shall be made available to the Department upon request.

017 [25 Pa. Code §127.441]**Operating permit terms and conditions.**

(a) The permittee shall maintain records of the following for Source ID 140:

- (1) The VOC and HAP emissions each month used to verify compliance with the annual VOC and HAP emission limitations in any 12 consecutive month period.
- (2) Condenser coolant inlet temperatures at least once per shift for the condensers identified in Source ID 140 when these condensers are required for control of emissions.
- (3) Documentation used to verify that the VOC emission rate for any uncontrolled vessel is less than 15 lbs per day.
- (4) Flow rate and pH readings of Control Device ID C153 scrubbing medium at least once per shift to verify compliance with the minimum flow rate and minimum pH requirements.
- (5) Flow rate readings of Control Device ID C155 scrubber water and make up water at least once per shift to verify compliance with the minimum water recycle rate and makeup water supply rate requirements.
- (6) The combination venturi jet/packed bed caustic scrubber (CL-1053) (Control Device ID C502) scrubbing solution and water flowrates and scrubbing solution pH at least once every 15 minutes to verify compliance with the minimum flowrate and minimum pH requirements.
- (7) Stack test reports to verify compliance with the HCl removal efficiency in Control Device ID C502

(b) These records shall be made available to the Department upon request and shall remain on file for five (5) years.

**SECTION D. Source Level Requirements****V. REPORTING REQUIREMENTS.****# 018 [25 Pa. Code §127.441]****Operating permit terms and conditions.**

The permittee shall submit semiannual reports to the Department of those processes that continue to operate (i.e., not subject to new batch charge stoppage and stable hold point alternative operating scenario) during thermal oxidizer (Control Device ID C500) or associated scrubber (Control Device ID C501) malfunctions or during annual planned TOU and/or associated scrubber maintenance to verify that each process emits less than 1.0 ton of VOCs in any 12 consecutive month period (from the sum of all process vents within a process) and emits HAPs less than the amount specified in 40 CFR Section 63.1254(a)(2)(i) (900 kg in any 365-day period) and to verify that the sum of all process vent emissions from all processes are less than 2.0 tons of VOCs in any 12 consecutive month period and 1,800 kg of HAPs in any 365-day period as specified in 40 CFR Section 63.1254(a)(2)(ii).

The semiannual reports shall be submitted to the Department no later than March 1 and September 1 for the six previous 12 consecutive month periods.

019 [25 Pa. Code §127.441]**Operating permit terms and conditions.**

The permittee shall submit to the Department on a semiannual basis the monthly VOC and HAP emissions from Source ID 140 verifying compliance with the annual VOC and HAP emission limitations in any 12 consecutive month period.

The semiannual reports shall be submitted to the Department no later than March 1 and September 1 for the six previous 12 consecutive month periods.

VI. WORK PRACTICE REQUIREMENTS.

No additional work practice requirements exist except as provided in other sections of this permit including Section B (Title V General Requirements).

VII. ADDITIONAL REQUIREMENTS.**# 020 [25 Pa. Code §127.441]****Operating permit terms and conditions.**

Pursuant to the best available technology provisions of 25 Pa. Code Sections 127.1 and 127.12, packed bed scrubber CL-1673 (Control Device ID C155) shall utilize water as the scrubbing medium and the scrubber water shall be recycled to the scrubber at a rate of not less than 38.1 gallons per minute with a makeup water supply rate of not less than 1.2 gallons per minute.

021 [25 Pa. Code §127.441]**Operating permit terms and conditions.**

Pursuant to the best available technology provisions of 25 Pa. Code Sections 127.1 and 127.12, the permittee shall operate packed bed scrubber CL-3520 (Control Device ID C153) as follows:

- (a) the scrubbing medium shall have a minimum flow rate through the scrubber (Control Device ID C153) of 50 gallons per minute.
- (b) the minimum pH of the scrubbing solution shall be 7.0.
- (c) the recycled scrubbing solution shall be changed out on a frequent enough basis so as to ensure proper operation of Control Device ID C153.

022 [25 Pa. Code §127.441]**Operating permit terms and conditions.**

Pursuant to the best available technology provisions of 25 Pa. Code Sections 127.1 and 127.12, the combination venturi jet/packed bed caustic scrubber (CL-1053) (Control Device ID C502) used to control the air contaminant emissions from RE-1022 of Source ID 140 shall comply with the following operating criteria:

- (a) maintain a minimum packed bed scrubbing solution pH of 7.0,
- (b) maintain a minimum scrubbing water flow rate to the venturi jet of 16 gallons per minute, and
- (c) maintain a minimum scrubbing solution flow rate to the packed bed of 6 gallons per minute.

**SECTION D. Source Level Requirements****# 023 [25 Pa. Code §127.441]****Operating permit terms and conditions.**

(a) Source ID 140 is a group of equipment used to manufacture pharmaceutical/chemical products and includes the following process vessels and pieces of equipment:

BN-1790	DR-1775	RE-1730*	ST-2700*	TA-1007	TA-1435*	TA-2665*
CE-1123*	DR-1811A	RE-2200*	ST-2710*	TA-1008	TA-1440*	TA-2668*
CE-1127*	DR-1811B	RE-2220*	ST-2920*	TA-1012	TA-1444*	TA-2680
CE-1260*	DR-2400*	RE-2620*	ST-2950*	TA-1015*	TA-1450*	TA-2690
CE-1430*	DR-2685	RE-2660*	SU-2890	TA-1025	TA-1473*	TA-2705*
CE-1560	EV-735*	RE-3010	TA-01*	TA-1030	TA-1479	TA-2715*
CE-2300*	EV-1230*	RE-3020	TA-09*	TA-1031*	TA-1505*	TA-2720*
CE-3033	EV-1701	RE-3120	TA-62	TA-1033*	TA-1520*	TA-2740*
CL-701*	EX-2640*	RE-3410	TA-67*	TA-1036*	TA-1522*	TA-2745*
CL-759*	EX-3030	RO-1140	TA-68*	TA-1050	TA-1530	TA-2750*
CL-765*	EX-3040	RO-1755	TA-83*	TA-1103	TA-1532*	TA-2755*
CL-1278*		RO-4040	TA-89*	TA-1130*	TA-1538*	TA-2770
CL-1280*	FD-1655*	SE-353	TA-603	TA-1154*	TA-1542*	TA-2775
CL-1633	FD-2650*	SE-702	TA-604	TA-1160*	TA-1548*	TA-2810*
CL-1791*	FD-2670*	SE-737	TA-618*	TA-1201*	TA-1550*	TA-2890*
CL-1795*	FD-3100*	SE-760*	TA-619*	TA-1224	TA-1625	TA-2905*
CL-2680	FD-3110	SE-1675	TA-627*	TA-1225*	TA-1635	TA-2920
CL-2800*	FP-2260	SE-1692	TA-628*	TA-1227*	TA-1639	TA-2955*
CL-3310	FP-3025	SE-1811	TA-637*	TA-1233	TA-1645*	TA-2960*
CL-3340	HP-3150	SE-3320	TA-638*	TA-1238*	TA-1650	TA-2965*
CL-4000	MI-1165	SE-3344	TA-663*	TA-1249*	TA-1665	TA-2970*
CL-4010	MT-1121*	ST-614*	TA-668*	TA-1250*	TA-1668	TA-2975*
CL-4020	PF-1440A	ST-615*	TA-723*	TA-1255*	TA-1669*	TA-3000
CL-4030	PF-1440B	ST-661*	TA-724*	TA-1257*	TA-1675	TA-3015
CO-1811	PF-1440C	ST-780*	TA-741	TA-1270*	TA-1682*	TA-3033
CR-1119*	PF-1648*	ST-785*	TA-746*	TA-1275*	TA-1687*	TA-3035*
DE-704*	PF-1649*	ST-1240*	TA-752*	TA-1288*	TA-1696*	TA-3075*
DE-787*	PF-1709*	ST-1245*	TA-764*	TA-1291*	TA-1747	TA-3130
DE-1282*	PF-1767	ST-1415*	TA-766	TA-1293*	TA-1751	TA-3300
DE-1706*	RE-1001*	ST-1421*	TA-771*	TA-1295	TA-1753	TA-3380
DE-2815*	RE-1004*	ST-1447*	TA-776*	TA-1297*	TA-1764	TA-3400
DE-2895*	RE-1022*	ST-1501*	TA-790*	TA-1301*	TA-1770	TA-3500
DE-3330	RE-1110	ST-1510*	TA-811*	TA-1303	TA-1782	TA-3510
DE-3360	RE-1210*	ST-1525*	TA-836*	TA-1305	TA-1804	UF-1761
DR-1470*	RE-1651*	ST-1631	TA-864*	TA-1403	TA-1811	UF-1801
DR-1625	RE-1676*	ST-2600*	TA-889*	TA-1409	TA-2310*	UF-3090
DR-1671	RE-1680*	ST-2630*	TA-1000*	TA-1426*	TA-2430*	UF-3140
DR-1675*	RE-1701	ST-2690*	TA-1005*	TA-1432*	TA-2645	UF-2250

(b) Pursuant to the best available technology provisions of 25 Pa. Code Sections 127.1 and 127.12, the air contaminant emissions from the above pieces of equipment marked with a * shall be controlled by the T-Thermal #LPV-14M thermal oxidizer (Control Device ID C500, referenced as IN-2050) equipped with two natural gas fired burners: one 13.5 MMBtu/hr modified (low nitrogen oxides, LPV-14M) burner and a 1.5 MMBtu/hr HV-4018 burner, followed by the associated Sub-X water-cooled quench and Ceilcote #SPT-54-120 packed bed scrubber (Control Device ID C501).

(c) The thermal oxidizer (Control Device ID C500) need not be used for control of air contaminant emissions from ST-661 and TA-2960 of Source ID 140 whenever there is hydrogen gas in the exhaust of ST-661 in sufficient quantity to create a potential explosion hazard.

(d) The permittee may voluntarily use the thermal oxidizer (Control Device ID C500, referenced as IN-2050) for the control of acetone emissions from the following sources during acetone recovery from the Impenem non-sterile process: CL-1633, ST-1631, TA-603, TA-1635 and TA-1639. This voluntary use was approved via RFD issued March 16, 2016.

**SECTION D. Source Level Requirements****# 024 [25 Pa. Code §127.441]****Operating permit terms and conditions.**

Pursuant to the best available technology provisions of 25 Pa. Code Sections 127.1 and 127.12 and the synthesized pharmaceutical provisions of 25 Pa. Code Section 129.68, during thermal oxidizer (Control Device ID C500) or associated scrubber (Control Device ID C501) malfunctions, an alternative operating scenario consistent with the site's Standard Operating Practices (SOP) Plan, and using vent condensers, as specified below, meeting 25 Pa. Code Section 129.68 requirements may be employed to complete the processing of batches or material currently in process to the next stable process hold point. However, no new batches may be charged, or processing initiated until the thermal oxidizer and associated scrubber is operational and is operating in accordance with the requirements contained in this plan approval. When the thermal oxidizer or associated scrubber is not available for control due to a malfunction, the permittee shall control the following vessels with the specified condensers at the specified coolant inlet temperatures when required for control to comply with 25 Pa. Code Section 129.68:

Equipment	Condenser**	Coolant Inlet Temperature
TA-864	CN-864	32°C
TA-1275	CN-1275	-20°C
RE-1022	CN-1024	-10°C
TA-1645	CN-1647	-10°C
TA-1520	CN-1527	-20°C
TA-1522	CN-1527	-20°C
ST-1510	CN-1513	-20°C
DR-1470	CN-1472	-20°C
ST-661	CN-661	-20°C
ST-2710	VPs*	-20°C
ST-2630	VPs*	-20°C
ST-2600	VPs*	-20°C
RE-2660	VPs*	-20°C
EX-2640	CN-2640	-20°C
ST-2950	CN-2955	-20°C
TA-637	VPs*	-20°C
ST-2690	VPs*	-20°C
FD-2650	VPs*	-20°C
TA-2665	VPs*	-20°C
FD-2670	VPs*	-20°C
TA-663	VPs*	-20°C
TA-668	VPs*	-20°C
TA-618	VPs*	-20°C
TA-2970	VPs*	-20°C
TA-614	VPs*	-20°C
ST-2700	VPs*	-20°C
ST-2705	VPs*	-20°C
TA-2960	CN-2962	+10°C
CE-2300	CN-2672	+10°C
RE-2220	CN-2210	-20°C
ST-615	CN-661	-20°C

*VP-2610, VP-2611, VP-2652, VP-2672 or VP-2678

**Those condensers listed for more than one vessel shall only control one vessel at any time unless multiple approved vessels are part of an equipment train (i.e. a unit operation such as distillation, steam/air stripping, extraction, etc.).

025 [25 Pa. Code §127.441]**Operating permit terms and conditions.**

(a) Pursuant to the best available technology provisions of 25 Pa. Code Sections 127.1 and 127.12, the air contaminant emissions from Source ID 140 shall be controlled as follows:

**SECTION D. Source Level Requirements**

- (1) A Buflovak model 105-94729 packed bed water scrubber (SCB-1781)*** shall control particulate matter emissions from DR-1775 and BN-1790.
- (2) A combination venturi jet/packed bed caustic scrubber (CL-1053) (Control Device ID C502) shall control the thionyl chloride, sulfur dioxide and hydrogen chloride emissions from RE-1022.
- (3) A water venturi jet scrubber (EJ-1673)*** in series with a packed bed scrubber (CL-1673) (identified as Control Device ID C155) equipped with a recirculation tank TA-1673 shall control triethylamine emissions from TA-1665.
- (4) A Ceilcote model SPT-12-60 wet scrubber (CL-1710)*** shall control the air contaminant emissions from the Anhydrous Hydrogen Chloride Charging Operation of Source ID 140. This operation was modified via an RFD approved June 13, 2017, said modification consisted of purging the hydrogen chloride charge lines directly to CL-1710.
- (5) The hydrogen chloride emissions from vessels TA-3500 and TA-3510 and associated drum quench station of Source ID 140 shall be controlled by packed bed scrubber CL-3520 (Ceilcote SPT-30-96) (Control Device ID C153).
- (6) The permittee shall utilize condenser CN-1024 for the removal of moisture from the exhaust of RE-1022.
- (7) The air contaminant emissions from the trim condenser on TA-776 shall be controlled by absolute filters (Control Device ID C132).

(b) Scrubbers signified with asterisks (***) in (a) above are collectively identified as Control Device ID C152.

026 [25 Pa. Code §127.441]**Operating permit terms and conditions.**

The permittee shall be allowed to make process changes to Source ID 140 provided these process changes do not increase the Source ID 140 emissions above the established permitted limits and no additional hazardous air pollutants are involved. The permittee shall advise the Department of these changes, but no formal approvals will be required provided the changes and resultant impact on actual and potential emissions from these changes are summarized to the Department annually.

027 [25 Pa. Code §127.441]**Operating permit terms and conditions.**

The Methylene Chloride Recovery operation of Source ID 140 shall not be operated during any period Control Device IDs C500 or C501 are not operational or are not operating in accordance with the best available technology (25 Pa. Code Sections 127.1 and 127.12) requirements contained herein; however, TA-1238 of the Methylene Chloride Recovery operation of Source ID 140 may continue to store (but not collect) methylene chloride and send it to the cilastatin process step during times of oxidizer downtime. Additionally, TA-1538 and TA-1548 of the Methylene Chloride Recovery operation of Source ID 140 may continue to collect and store methylene chloride wastes during oxidizer downtime provided the wastes are collected and stored under a water blanket as described in the application and supplemental materials submitted for plan approval, 49-00007E. During any period Control Device IDs C500 or C501 are not operational (or are not operating in accordance with the best available technology requirements contained herein), the wastewater stripping operation of Source ID 140 shall be discontinued.

028 [25 Pa. Code §127.441]**Operating permit terms and conditions.**

Vessels CL-2800, TA-2810, and DE-2815 of the CL-2800 wastewater stripping system shall only be operated during times Control Device ID C500 is operational.

029 [25 Pa. Code §127.441]**Operating permit terms and conditions.**

[Additional authority for this permit condition is derived from 40 CFR Part 63, Subpart GGG, Sections 63.1250 - 63.1260]

Source ID 140 is subject to Subpart GGG of the National Emission Standards for Hazardous Air Pollutants for Source Categories, Pharmaceuticals Production, 40 CFR Part 63 Sections 63.1250 - 63.1260. The permittee shall comply with all applicable requirements of this Subpart of the National Emission Standards for Hazardous Air Pollutants for Source Categories, including any recordkeeping and reporting requirements and shall comply with the provisions of the Notification of Compliance Status Reports (initial NOCSR dated March 14, 2003).

030 [25 Pa. Code §127.441]**Operating permit terms and conditions.**

Source ID 140 is subject to the compliance assurance monitoring (CAM) requirements of 40 CFR Part 64. The permittee shall comply with all applicable requirements of 40 CFR Sections 64.1 through 64.10.

**SECTION D. Source Level Requirements****# 031 [25 Pa. Code §127.441]****Operating permit terms and conditions.**

Pursuant to the best available technology provisions in 25 Pa. Code Sections 127.1 and 127.12, when the thermal oxidizer or associated scrubber is not operational or when the thermal oxidizer or associated scrubber is not operating in accordance with the requirements contained in this operating permit, TA-1031 may only be used for processing if administrative controls (i.e., closing of the vent line to the thermal oxidizer with no bypass to atmosphere and closing of inlet line after methylene chloride is loaded) are implemented that prevent point source methylene chloride emissions to the atmosphere.

032 [25 Pa. Code §127.441]**Operating permit terms and conditions.**

Pursuant to the best available technology provisions in 25 Pa. Code Sections 127.1 and 127.12, when the thermal oxidizer or associated scrubber is not operational or when the thermal oxidizer or associated scrubber is not operating in accordance with the requirements contained in this operating permit, TA-1542 may only be used for processing if administrative controls (i.e., closing of the vent line to the thermal oxidizer with no bypass to atmosphere and closing of inlet line after sufficient methylene chloride [1500 gallons maximum] is loaded to process the batch to the next stable hold point) are implemented that prevent point source methylene chloride emissions to the atmosphere.

033 [25 Pa. Code §127.441]**Operating permit terms and conditions.**

Pursuant to the best available technology provisions in 25 Pa. Code Sections 127.1 and 127.12, the permittee shall use load modeling for the TOU (IN-2050) to ensure that overloading of the TOU does not occur. Records of internal procedures and load modeling and matrix results shall be maintained and shall be made available to the Department upon request.

034 [25 Pa. Code §127.441]**Operating permit terms and conditions.**

Pursuant to the best available technology provisions of 25 Pa. Code Sections 127.1 and 127.12, the permittee shall comply with 25 Pa. Code Section 129.68 for the VOC emissions not controlled by the thermal oxidizer (Control Device ID C500).

035 [25 Pa. Code §127.441]**Operating permit terms and conditions.**

The Department acknowledges that there are fugitive VOC emissions from the filter vessels PF-1648 and PF-1649 of Source ID 140 during the manual changeout of filters. The loss of these fugitive VOC emissions to the atmosphere is acceptable to the Department.

*** **Permit Shield in Effect.** ***

**SECTION D. Source Level Requirements**

Source ID: 145

Source Name: THERMAL OXIDIZERS AND SCRUBBER UNITS

Source Capacity/Throughput:

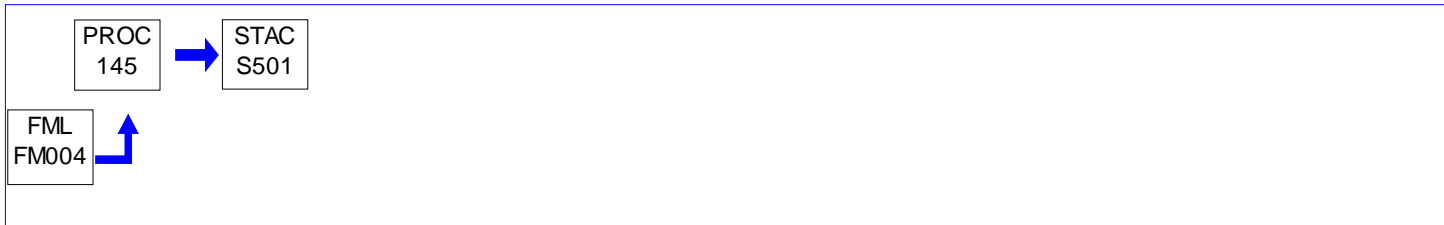
**I. RESTRICTIONS.****Emission Restriction(s).****# 001 [25 Pa. Code §127.441]****Operating permit terms and conditions.**

Pursuant to 25 Pa. Code Section 123.21, no person may permit the emission from the exhaust of Control Device ID C501 into the outdoor atmosphere in a manner that the concentration of sulfur oxides (SO_x), expressed as SO₂, in the effluent gas is in excess of 500 parts per million, by volume, dry basis.

002 [25 Pa. Code §127.441]**Operating permit terms and conditions.**

The air contaminant emissions from the T-Thermal #LPV-14M thermal oxidizer (Control Device ID C500), Sub-X water-cooled quench and Ceilcote #SPT-54-120 packed bed scrubber (Control Device ID C501), or equivalent, shall not exceed the following limits:

Pollutant	Emission Limit (tons in any 12 consecutive month period)
carbon monoxide	10.9
VOCs	1.0
sulfur oxides, as SO ₂	8.8
nitrogen oxides, expressed as NO ₂	17.0
particulate matter	6.4
PM ₁₀	6.4

003 [25 Pa. Code §127.441]**Operating permit terms and conditions.**

[Compliance with the requirement specified in this streamlined permit condition assures compliance with the provisions in 25 Pa. Code Section 123.13]

Pursuant to the best available technology provisions of 25 Pa. Code Sections 127.1 and 127.12, at any time that Control Device IDs C500 and C501 are being used to control air contaminant emissions from TA-812, TA-1548, TA-1238, TA-1250, HE-1284, TA-1297, ST-1245 or TA-1538 of Source ID 140, the permittee shall maintain a particulate matter emission rate in the packed bed scrubber (Control Device ID C501) exhaust of not greater than 0.03 grains per dry standard cubic feet.

004 [25 Pa. Code §127.441]**Operating permit terms and conditions.**

Pursuant to the best available technology provisions of 25 Pa. Code Sections 127.1 and 127.12, at any time that Control Device IDs C500 and C501 are being used to control air contaminant emissions from TA-812, TA-1548, TA-1238, TA-1250, HE-1284, TA-1297, ST-1245, CL-1280 or TA-1538 of Source ID 140, the permittee shall maintain a total hydrocarbon concentration in the packed bed scrubber (Control Device ID C501) exhaust of not greater than 50 ppmv.

Fuel Restriction(s).**# 005 [25 Pa. Code §127.441]****Operating permit terms and conditions.**

Control Device ID C500 shall be fired only on natural gas.

**SECTION D. Source Level Requirements****Control Device Efficiency Restriction(s).****# 006 [25 Pa. Code §127.441]****Operating permit terms and conditions.**

Pursuant to the best available technology provisions of 25 Pa. Code Sections 127.1 and 127.12, at any time that Control Device IDs C500 and C501 are being used to control air contaminant emissions from Source IDs 140 and 155, the permittee shall comply with the following operating criteria for Control Device IDs C500 and C501:

- (a) maintain a minimum combined VOC destruction/removal efficiency of 99.9%,
- (b) maintain a minimum combined methylene chloride destruction/removal efficiency of 99.99%, and
- (c) maintain a minimum hydrogen chloride removal efficiency of 99%.

II. TESTING REQUIREMENTS.

No additional testing requirements exist except as provided in other sections of this permit including Section B (Title V General Requirements).

III. MONITORING REQUIREMENTS.**# 007 [25 Pa. Code §127.441]****Operating permit terms and conditions.**

Pursuant to compliance assurance monitoring requirements of 40 CFR Section 64.6 and the best available technology provisions of 25 Pa. Code Sections 127.1 and 127.12, thermal oxidizer IN-2050 (Control Device ID C500) shall be equipped with a continuous temperature monitor and recorder, which shall accurately monitor and record the oxidizer's outlet combustion chamber temperature. The outlet combustion chamber temperature of the oxidizer shall be maintained at a minimum of 1800 degrees F. In addition, the oxidizer shall be equipped with an alarm that will activate should the monitor ever indicate a temperature below 1800 degrees F.

008 [25 Pa. Code §127.441]**Operating permit terms and conditions.**

The final exhaust stack (downstream of the packed bed scrubber) shall be equipped with oxygen and carbon monoxide monitors that shall accurately monitor the oxygen and carbon monoxide content of the final stack exhaust whenever Control Device ID C500 is in use.

009 [25 Pa. Code §127.441]**Operating permit terms and conditions.**

Pursuant to the compliance assurance monitoring requirements of 40 CFR Section 64.6, the permittee shall conduct the monitoring and fulfill the other obligations (i.e., proper monitor maintenance, corrective actions, etc.) specified in 40 CFR Section 64.7.

010 [25 Pa. Code §127.441]**Operating permit terms and conditions.**

Pursuant to the compliance assurance monitoring requirements of 40 CFR Section 64.6, the oxidizer's (Control Device ID C500) combustion chamber temperature monitoring device shall be calibrated annually and shall be accurate to within +/- 0.75 percent of the temperature measured in degrees Celsius or +/- 2.5 degrees C, whichever is greater.

011 [25 Pa. Code §127.441]**Operating permit terms and conditions.**

Pursuant to the compliance assurance monitoring requirements of 40 CFR Section 64.6, the scrubber's (Control Device ID C501) pH and flow rate monitoring devices shall be calibrated annually and the flow rate monitoring device shall be accurate to within +/- 10 percent of the design scrubber liquid flow rate.

IV. RECORDKEEPING REQUIREMENTS.**# 012 [25 Pa. Code §127.441]****Operating permit terms and conditions.**

- (a) The permittee shall maintain records of the following for Source ID 145:

**SECTION D. Source Level Requirements**

- (1) Calculations or stack test reports used to verify compliance with the SO₂ and particulate emissions limitations;
- (2) Calculations or stack test reports to verify compliance with the ppm hydrocarbon concentration limitation for the exhaust of Control Device ID C501;
- (3) The supporting calculations/documentation verifying compliance with the 12 consecutive month carbon monoxide, VOCs, sulfur oxides (as SO₂), nitrogen oxides (expressed as NO₂), particulate matter and PM₁₀ emission limitations for the T-Thermal #LPV-14V thermal oxidizer (Control Device ID C500), Sub-X water-cooled quench and Ceilcote #SPT-54-120 packed bed scrubber (Control Device ID C501);
- (4) Pursuant to the compliance assurance monitoring requirements of 40 CFR Sections 64.6 and 64.9, Control Device ID C501 caustic scrubbing solution flow rate and pH on a continuous basis. Also, records of monitor performance data (calibrations, monitor accuracy, monitor malfunctions, etc.) and corrective actions taken in the event of an excursion from the scrubber's pH and flow rate requirements specified in this operating permit;
- (5) Pursuant to the compliance assurance monitoring requirements of 40 CFR Sections 64.6 and 64.9, Control Device ID C500 combustion chamber exit gas temperature on a continuous basis. Also, records of monitor performance data (calibrations, monitor accuracy, monitor malfunctions, etc.) and corrective actions taken in the event of an excursion from the oxidizer's outlet combustion chamber temperature requirement specified in this operating permit;
- (6) Oxygen and CO content of the gas stream leaving Control Device ID C500 on a continuous basis;
- (7) Stack test reports to verify compliance with the VOC and methylene chloride destruction and removal efficiencies across Control Device IDs C500 and C501;
- (8) Stack test reports to verify compliance with the HCl removal efficiency of Control Device ID C501.
- (9) With respect to thermal oxidizer IN-2050 (Control Device ID C500), the permittee shall maintain records verifying that the control device is being maintained and operated in accordance with the manufacturer's specifications and with good operating practices. Additional authority of this condition is pursuant to 25 Pa. Code Sections 129.100(d) and 129.115(f).

(b) These records shall be made available to the Department upon request and shall remain on file for a minimum of five years.

V. REPORTING REQUIREMENTS.**# 013 [25 Pa. Code §127.441]****Operating permit terms and conditions.**

The permittee shall submit semiannual reports of the supporting calculations/documentation verifying compliance with the 12 consecutive month carbon monoxide, VOCs, sulfur oxides (as SO₂), nitrogen oxides (expressed as NO₂), particulate matter and PM₁₀ emission limitations for the T-Thermal #LPV-14V thermal oxidizer (Control Device ID C500), Sub-X water-cooled quench and Ceilcote #SPT-54-120 packed bed scrubber (Control Device ID C501).

The semiannual reports shall be submitted to the Department no later than September 1 and March 1 for the six previous 12 consecutive month periods.

014 [25 Pa. Code §127.441]**Operating permit terms and conditions.**

Pursuant to the compliance assurance monitoring (CAM) requirements of 40 CFR Sections 64.6 and 64.9, the permittee shall submit semiannual reports of the following:

- (a) Summary information on the number, duration and cause (including unknown cause, if applicable) of CAM excursions and the corrective actions taken; and
- (b) Summary information on the number, duration and cause (including unknown cause, if applicable) for CAM monitor downtime incidents (other than downtime associated with zero and span or other calibration checks, if applicable).

The reports shall be submitted to the Department no later than March 1 (for July through December of the previous year) and September 1 (for January through June of the current year).

VI. WORK PRACTICE REQUIREMENTS.**# 015 [25 Pa. Code §127.441]****Operating permit terms and conditions.**

Pursuant to 25 Pa. Code Sections 129.97(c) and 129.112(c), the permittee shall maintain and operate thermal oxidizer IN-

**SECTION D. Source Level Requirements**

2050 (Control Device ID C500) in accordance with the manufacturer's specifications and with good operating practices.

VII. ADDITIONAL REQUIREMENTS.**# 016 [25 Pa. Code §127.441]****Operating permit terms and conditions.**

Source ID 145 consists of a T-Thermal model LPV-14M thermal oxidizer (Control Device ID C500, referenced as IN-2050) equipped with two natural gas fired burners: one 13.5 MMBtu/hr modified (low nitrogen oxides, LPV-14M) burner and a 1.5 MMBtu/hr HV-4018 burner, followed by the associated Sub-X water-cooled quench and Ceilcote model SPT-54-120 packed bed scrubber (Control Device ID C501).

017 [25 Pa. Code §127.441]**Operating permit terms and conditions.**

Pursuant to the compliance assurance monitoring requirements of 40 CFR Section 64.6 and the best available technology requirements of 25 Pa. Code Sections 127.1 and 127.12, the Ceilcote model SPT-54-120 packed bed scrubber (Control Device ID C501) shall be equipped with continuous flow, pH and pressure drop monitors that shall accurately monitor the scrubbing solution's pH and flow rate and the pressure drop across the scrubber. The scrubber shall comply with the following operating criteria:

- (a) utilize a caustic solution as the scrubbing solution,
- (b) maintain a scrubbing solution pH of at least 7, and
- (c) maintain a scrubbing solution flow rate of at least 120 gallons per minute.

The scrubber shall additionally be equipped with an alarm that will alert the operator should the monitor(s) ever indicate a pH or flow rate below the limits specified above.

***** Permit Shield in Effect. *****

**SECTION D. Source Level Requirements**

Source ID: 155

Source Name: BULK STORAGE TANKS

Source Capacity/Throughput:

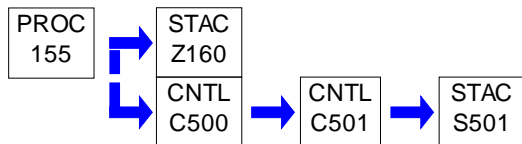
**I. RESTRICTIONS.****Emission Restriction(s).****# 001 [25 Pa. Code §127.441]****Operating permit terms and conditions.**

Pursuant to the best available technology provisions of 25 Pa. Code Sections 127.1 and 127.12, the following storage vessels of Source ID 155 shall not exceed the following volatile organic compound (VOC) emission limits as specified:

Tank Maximum VOC Emissions (tons in any 12 consecutive month period)

TA-104	1.18
TA-109	1.18
TA-114	1.18

002 [25 Pa. Code §127.441]**Operating permit terms and conditions.**

The hydrochloric acid emissions from TA-824 shall not exceed 0.024 tons in any 12 consecutive month period.

003 [25 Pa. Code §127.441]**Operating permit terms and conditions.**

The hazardous air pollutant emissions from TA-876 shall not exceed 0.8 tons in any 12 consecutive month period.

Throughput Restriction(s).**# 004 [25 Pa. Code §127.441]****Operating permit terms and conditions.**

Pursuant to the best available technology provisions of 25 Pa. Code Sections 127.1 and 127.12, the bulk storage tanks of Source ID 155 that are not controlled by the thermal oxidizer (Control Device ID C500, referenced as IN-2050) shall not store VOCs with a vapor pressure greater than tetrahydrofuran (THF) (2.51 psi at 68oF).

Control Device Efficiency Restriction(s).**# 005 [25 Pa. Code §127.441]****Operating permit terms and conditions.**

[Additional authority for this permit condition is derived from 25 Pa. Code Sections 127.1 and 127.12, 129.57 and 40 CFR 60.112b(a)(3)(ii).]

The condenser (Control Device ID C166) and pressure control valve (Control Device ID C167) shall maintain a combined volatile organic compound removal efficiency of at least 95% during any and all times this control option is being used to control emissions from TA-862. To achieve this minimum volatile organic compound removal efficiency, the condenser and pressure control valve shall be operated as follows:

- The coolant supplied to Control Device ID C166 shall be maintained at or below +10 degrees Celsius.
- TA-862 shall have a pressure relief valve (Control Device ID C167) which is maintained in good operating condition and which is set to release at no less than 10 psig of pressure.
- Control Device ID C167 shall be set to release at no less than 0.3 psig of vacuum or the highest possible vacuum in accordance with state or local fire codes or the National Fire Prevention Association guidelines or other national consensus standards acceptable to the Department.

**SECTION D. Source Level Requirements****II. TESTING REQUIREMENTS.**

No additional testing requirements exist except as provided in other sections of this permit including Section B (Title V General Requirements).

III. MONITORING REQUIREMENTS.**# 006 [25 Pa. Code §127.441]****Operating permit terms and conditions.**

[Additional authority for this permit condition is derived from the reasonably available control technology provisions of 25 Pa. Code Sections 129.91 - 129.95. Compliance with this streamlined condition ensures compliance with 25 Pa. Code Sections 129.111-129.115.]

The sources of fugitive emissions of Source ID 155 shall follow the monitoring and repair requirements as described in Section 6.3.2 of the VOC RACT application as follows:

Fugitive Source	Monitoring and Repair Option
South Tank Farm	LDAR I
Factory 6/7 Tank Farm	LDAR I
Factory 3/4 Tank Farm	LDAR I

The LDAR I program shall include annual component monitoring using Method 21 of 40 CFR Part 60, Appendix A with a leak definition of 10,000 ppm for all components. The permittee shall keep records of component monitoring, inspections and repairs (i.e., readings, dates, work performed, etc.); the records shall be retained for a minimum of five years and shall be made available to the Department upon request.

007 [25 Pa. Code §127.441]**Operating permit terms and conditions.**

[Additional authority for this permit condition is derived from 40 CFR 60.113b(c)(1).]

The fume header system associated with TA-862 shall be equipped with a monitor to continuously measure the vacuum in the closed vent header system. Loss of vacuum during normal operations (i.e., not during startup or shutdown of the unit) requires investigation into the cause. If determined that loss of vacuum is due to a leak in the closed vent header system, the leak shall be repaired as soon as practicable. A first attempt at repair shall be made no later than 5 calendar days after the leak is detected. Repairs shall be completed no later than 15 calendar days after the leak is detected.

008 [25 Pa. Code §127.441]**Operating permit terms and conditions.**

Pursuant to the compliance assurance monitoring requirements of 40 CFR Section 64.6, condenser CN-862A (Control Device ID C166) shall be equipped with a temperature monitor, which shall accurately measure the inlet coolant temperature to the condenser on a continuous basis. The coolant inlet temperature to condenser CN-862A shall not exceed 10 degrees C.

009 [25 Pa. Code §127.441]**Operating permit terms and conditions.**

Pursuant to the compliance assurance monitoring requirements of 40 CFR Section 64.6, the condenser's (Control Device ID C166) coolant temperature monitoring device shall be calibrated annually and shall be accurate to within +/- 2 percent of the temperature measured in degrees Celsius or +/- 2.5 degrees C, whichever is greater.

010 [25 Pa. Code §127.441]**Operating permit terms and conditions.**

Pursuant to the compliance assurance monitoring requirements of 40 CFR Section 64.6, the permittee shall conduct the monitoring and fulfill the other obligations (i.e., proper monitor maintenance, corrective actions, etc.) specified in 40 CFR Section 64.7.

**SECTION D. Source Level Requirements****IV. RECORDKEEPING REQUIREMENTS.****# 011 [25 Pa. Code §127.441]****Operating permit terms and conditions.**

The permittee shall maintain records of the identity of the volatile organic compounds stored in each of the tanks identified as part of the following tank farms: South Tank Farm, Factory 6/7 Tank Farm and Factory 3/4 Tank Farm of Source ID 155. In addition, the permittee shall keep records of the vapor pressure of each storage tank of Source ID 155 that is not controlled by the thermal oxidizer (Control Device ID C500, referenced as IN-2050) to verify compliance with the VOC vapor pressure limitation.

These records shall be retained for a minimum of five (5) years and shall be made available to the Department upon request.

012 [25 Pa. Code §127.441]**Operating permit terms and conditions.**

[Additional authority for this permit condition is derived from 40 CFR 60.110b - 60.117b.]

The permittee shall keep readily accessible records showing the dimension of each storage vessel and an analysis showing the capacity of each storage vessel of Source ID 155.

013 [25 Pa. Code §127.441]**Operating permit terms and conditions.**

The permittee shall keep records of the VOC or HAP emissions each month from the following tanks to verify compliance with the annual VOC or HAP emission limitations in any 12 consecutive month period for TA-104, TA-109, TA-114, TA-876 and TA-824 of Source ID 155.

These records shall be retained on file for a minimum of five (5) years and made available to the Department upon request.

014 [25 Pa. Code §127.441]**Operating permit terms and conditions.**

If vacuum loss occurs in the fume header system of TA-862, the permittee shall record the date, time and duration of loss of vacuum and vacuum reading in the vent header system and subsequent investigation results and date of completion of leak repair if applicable.

The records shall be retained for a minimum of 5 years and shall be made available to the Department upon request.

015 [25 Pa. Code §127.441]**Operating permit terms and conditions.**

Pursuant to the compliance assurance monitoring requirements of 40 CFR Sections 64.6 and 64.9, the permittee shall maintain records of the inlet coolant temperature of Control Device ID C166 at least once per shift when required for emissions control. Also, the permittee shall maintain records of monitor performance data (calibrations, monitor accuracy, monitor malfunctions, etc.) and corrective actions taken in the event of an excursion from the condenser's inlet coolant temperature requirement specified in this plan approval.

These records shall be made available to the Department upon request and shall remain on file for a minimum of five years.

V. REPORTING REQUIREMENTS.**# 016 [25 Pa. Code §127.441]****Operating permit terms and conditions.**

Pursuant to compliance assurance monitoring (CAM) requirements of 40 CFR Sections 64.6 and 64.9, the permittee shall submit semiannual reports of the following for TA-862 and associated condenser (Control Device ID C166):

- (a) Summary information on the number, duration and cause (including unknown cause, if applicable) of CAM excursions and the corrective actions taken; and
- (b) Summary information on the number, duration and cause (including unknown cause, if applicable) for CAM monitor downtime incidents (other than downtime associated with zero and span or other calibration checks, if applicable).

**SECTION D. Source Level Requirements**

The reports shall be submitted to the Department no later than March 1 (for July through December of the previous year) and September 1 (for January through June of the current year).

017 [25 Pa. Code §127.441]**Operating permit terms and conditions.**

The permittee shall submit semiannual reports of the monthly VOC or HAP emissions from the following tanks verifying compliance with the annual VOC or HAP emission limitations in any 12 consecutive month period for TA-104, TA-109, TA-114, TA-876 and TA-824 of Source ID 155.

The semiannual reports shall be submitted to the Department no later than March 1 and September 1 for the six previous 12 consecutive month periods.

018 [25 Pa. Code §127.441]**Operating permit terms and conditions.**

Pursuant to 40 CFR Section 60.4 of the Standards of Performance, the submission of all requests, reports, applications, submittals and other communications required by the Standards of Performance shall be made to both the Department and the Environmental Protection Agency. The EPA copies may be sent to:

R3_Air_Apps_and_Notices@epa.gov

VI. WORK PRACTICE REQUIREMENTS.

No additional work practice requirements exist except as provided in other sections of this permit including Section B (Title V General Requirements).

VII. ADDITIONAL REQUIREMENTS.**# 019 [25 Pa. Code §127.441]****Operating permit terms and conditions.**

Source ID 155 consists of the following bulk storage tanks at the locations as specified:

South Tank Farm

TA-100 TA-101 TA-102 TA-104 TA-106 TA-107 TA-108 TA-109 TA-110 TA-111

TA-112 TA-113 TA-114 TA-115 TA-116 TA-118 TA-601 TA-606

TA-607 TA-610 TA-672 TA-681 TA-690

Factory 6/7 Tank Farm

TA-801 TA-812 TA-814 TA-824 TA-854 TA-858 TA-807

TA-860 TA-866 TA-868 TA-876 TA-878 TA-806

TA-372 TA-373 TA-862 (30,000 gallon, stainless steel, horizontal, steam-heated waste solvent storage vessel)

020 [25 Pa. Code §127.441]**Operating permit terms and conditions.**

The use of vapor return lines on vessels TA-601, TA-610, TA-672, TA-118, TA-681 and TA-690 of Source ID 155 is voluntary on the part of the permittee and their use may be discontinued at any time.

021 [25 Pa. Code §127.441]**Operating permit terms and conditions.**

In accordance with the mixed heptanes solvent RFD approved May 21, 2007, a vapor return line shall be used to control the air contaminant emissions from the loading of mixed heptanes to TA-113.

022 [25 Pa. Code §127.441]**Operating permit terms and conditions.**

The permittee may change the contents of the storage tanks of Source ID 155, except where specifically prohibited, provided the permittee maintains compliance with the emission limitations contained herein, the vapor pressure limitation contained herein, the Pharmaceutical MACT (40 CFR Part 63, Subpart GGG) requirements, the storage tank NSPS (40 CFR Part 60

**SECTION D. Source Level Requirements**

Subpart Kb) requirements and all applicable provisions of 25 Pa. Code Chapters 121 - 129 and 131 - 145.

023 [25 Pa. Code §127.441]**Operating permit terms and conditions.**

[Compliance with the requirement specified in this streamlined permit condition assures compliance with the reasonably available control technology (RACT) VOC emission limit of 0.13 tons in any 12 consecutive month period for TA-860]

Pursuant to the best available technology provisions of 25 Pa. Code Sections 127.1 and 127.12, the air contaminant emissions from the following tanks of Source ID 155 shall be controlled by the T-Thermal model LPV-14M thermal oxidizer (Control Device ID C500, referenced as IN-2050) equipped with two natural gas fired burners: one 13.5 MMBtu/hr modified (low nitrogen oxides, LPV-14M) burner and a 1.5 MMBtu/hr HV-4018 burner, followed by the associated Sub-X water-cooled quench and Ceilcote model SPT-54-120 packed bed scrubber (Control Device ID C501):

TA-854, TA-101, TA-814, TA-860, TA-876, TA-862, TA-858, TA-807, TA-806 and TA-812

024 [25 Pa. Code §127.441]**Operating permit terms and conditions.**

Pursuant to the best available technology provisions of 25 Pa. Code Sections 127.1 and 127.12, during thermal oxidizer (Control Device ID C500) or associated scrubber (Control Device ID C501) malfunctions, an alternative operating scenario consistent with the site's Standard Operating Practices (SOP) may be employed to complete the processing of batches or material currently in process to the next stable process hold point. However, no raw material tank filling shall be initiated for those tanks required to be controlled by the thermal oxidizer until the thermal oxidizer and associated scrubber is operational and is operating in accordance with the requirements contained in this operating permit. When the thermal oxidizer or associated scrubber is not available for control due to an unplanned outage, the permittee shall control TA-862 with a condenser (Control Device ID C166, referenced as CN-862A) and a pressure control valve (Control Device ID C167).

025 [25 Pa. Code §127.441]**Operating permit terms and conditions.**

A number of tanks of Source ID 155, as specified in the permittee's Notification of Compliance Status Reports (NOCSRs) submitted to the Department (initial NOCSR dated March 14, 2003), are subject to Subpart GGG of the National Emission Standards for Hazardous Air Pollutants for Source Categories, Pharmaceuticals Production, 40 CFR Part 63, Sections 63.1250 - 63.1260. The permittee shall comply with all applicable requirements of 40 CFR Part 63, Subpart GGG.

026 [25 Pa. Code §127.441]**Operating permit terms and conditions.**

[Additional authority for this permit condition is derived from 40 CFR 60.110b - 60.117b.]

The following storage vessels of Source ID 155 are subject to Subpart Kb of the Federal Standards of Performance for New Stationary Sources, 40 CFR Part 60 Sections 60.110b - 60.117b. The permittee shall comply with all applicable requirements of this Subpart of the Standards of Performance for the following storage vessels of Source ID 155:

TA-100	TA-112	TA-610
TA-101	TA-113	TA-672
TA-102	TA-114	TA-681
TA-106	TA-115	TA-690
TA-107	TA-116	TA-814
TA-108		TA-860
TA-109	TA-601	TA-862
TA-110	TA-606	
TA-111	TA-607	

027 [25 Pa. Code §127.441]**Operating permit terms and conditions.**

TA-862 of Source ID 155 is subject to the compliance assurance monitoring (CAM) requirements of 40 CFR Part 64. The permittee shall comply with all applicable requirements of 40 CFR Sections 64.1 through 64.10.

**SECTION D. Source Level Requirements****# 028 [25 Pa. Code §127.441]****Operating permit terms and conditions.**

Pursuant to the reasonably available control technology provisions of 25 Pa. Code Sections 129.57 and 129.91 - 129.95 and the best available technology provisions of 25 Pa. Code Sections 127.1 and 127.12, each of the storage tanks of Source ID 155 containing a VOC or HAP shall have a pressure relief valve which is maintained in good operating condition and which is set to release at no less than 0.7 psig of pressure or 0.3 psig of vacuum or the highest possible pressure and vacuum in accordance with state or local fire codes or the National Fire Prevention Association guidelines or other national consensus standards acceptable to the Department. Compliance with this streamlined condition ensures compliance with 25 Pa. Code Sections 129.111-129.115.

***** Permit Shield in Effect. *****

**SECTION D. Source Level Requirements**

Source ID: 162

Source Name: FUEL STORAGE TANKS

Source Capacity/Throughput:

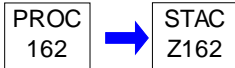
**I. RESTRICTIONS.****Emission Restriction(s).****# 001 [25 Pa. Code §127.441]****Operating permit terms and conditions.**

Pursuant to the reasonably available control technology provisions of 25 Pa. Code Sections 129.91 - 129.95, each of the fuel storage tanks of Source ID 162 identified below shall have throughput limitations and VOC emission limitations as follows:

Tank Number	Maximum Throughput (gallons in any 12 consecutive month period)	Maximum VOC Emissions (tons in any 12 consecutive month period)
TA-300	150,000	0.5
TA-301	900,000	0.0016
TA-304-1	200,000	0.0006

Compliance with this streamlined condition ensures compliance with 25 Pa. Code Sections 129.111-129.115.

002 [25 Pa. Code §127.441]**Operating permit terms and conditions.**

The VOC emissions from TA-5000 of Source ID 162 shall not exceed 0.01 tons in any 12 consecutive month period.

II. TESTING REQUIREMENTS.

No additional testing requirements exist except as provided in other sections of this permit including Section B (Title V General Requirements).

III. MONITORING REQUIREMENTS.**# 003 [25 Pa. Code §127.441]****Operating permit terms and conditions.**

[Additional authority for this permit condition is derived from the reasonably available control technology provisions of 25 Pa. Code Sections 129.91 - 129.95. Compliance with this streamlined condition ensures compliance with 25 Pa. Code Sections 129.111-129.115.]

The sources of fugitive emissions of Source ID 162 shall follow the monitoring and repair requirements as described in Sections 6.3.1 of the VOC RACT application (except for fuel oil storage tank TA-5000):

Fugitive Source: Monitoring and Repair Option:

Fuel Storage Tanks Routine inspections/maintenance

The permittee shall keep records of the inspections and repairs (dates, work performed, etc.). The records shall be retained for a minimum of five years and shall be made available to the Department upon request.

**SECTION D. Source Level Requirements****IV. RECORDKEEPING REQUIREMENTS.****# 004 [25 Pa. Code §127.441]****Operating permit terms and conditions.**

(a) The permittee shall maintain records of the following operating parameters for Source ID 162:

- (1) Emissions calculations or emission test reports for the fuel storage tanks of Source ID 162 to verify compliance with the VOC emissions limitations in any 12 consecutive month period.
- (2) The annual fuel deliveries (which shall indicate the quantities and types of fuels delivered) in each of the tanks of Source ID 162.
- (3) Throughputs (in gallons) for the fuel storage tanks of Source ID 162 to verify compliance with the throughput limitations in any 12 consecutive month period.
- (4) Calculations used to determine the vapor pressure under actual storage conditions for the contents of each storage tank having a capacity equal to or greater than 2000 gallons and not equipped with a pressure relief valve set as specified in 25 Pa. Code Section 129.57.

(b) These records shall be retained for a minimum of five (5) years and shall be made available to the Department upon request.

005 [25 Pa. Code §127.441]**Operating permit terms and conditions.**

[Additional authority for this permit condition is derived from 40 CFR Part 60, Subpart Kb, Section 60.116b(b)]

The permittee shall keep readily accessible records showing the dimension of TA-5000 and an analysis showing the capacity of TA-5000.

V. REPORTING REQUIREMENTS.**# 006 [25 Pa. Code §127.441]****Operating permit terms and conditions.**

The permittee shall submit to the Department on a semiannual basis records of the following for Source ID 162:

- (a) Emission calculations or emission test reports verifying compliance with the VOC emission limitations in any 12 consecutive month period.
- (b) Records of throughputs for the fuel storage tanks verifying compliance with the throughput limitations in any 12 consecutive month period.

All semiannual reports shall be submitted to the Department no later than March 1 and September 1 for the six previous 12 consecutive month periods.

VI. WORK PRACTICE REQUIREMENTS.

No additional work practice requirements exist except as provided in other sections of this permit including Section B (Title V General Requirements).

VII. ADDITIONAL REQUIREMENTS.**# 007 [25 Pa. Code §127.441]****Operating permit terms and conditions.**

Source ID 162 consists of one 500,000 gallon capacity #2 fuel oil storage tank identified as TA-5000, three #2 fuel oil storage tanks identified as follows: TA-301, TA-304-1 (formerly TA-305) and TA-304-2, and one 500 gallon capacity gasoline storage tank identified as TA-300. These tanks shall only be used for the storage of the specific fuels identified in this condition.

***** Permit Shield in Effect. *****

**SECTION D. Source Level Requirements**

Source ID: 165

Source Name: GLYCOL TANKS

Source Capacity/Throughput:

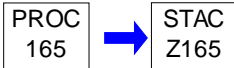
**I. RESTRICTIONS.****Emission Restriction(s).****# 001 [25 Pa. Code §127.441]****Operating permit terms and conditions.**

[Additional authority for this permit condition is derived from 25 Pa. Code Sections 129.91 - 129.95, 129.96-129.100 and 129.111 – 129.115.]

(a) Pursuant to 25 Pa. Code Section 129.91, the potential to emit volatile organic compounds from Source ID 165 shall never exceed 3 pounds per hour or 15 pounds per day in any 12 consecutive month period. Should any of these limitations ever be exceeded, a detailed RACT analysis which meets the criteria specified in Section 129.92 of 25 Pa. Code Chapter 129 must be submitted to the Department for Source ID 165.

(b) Pursuant to 25 Pa. Code Sections 129.97(c)(2) and 129.112(c)(2), the potential to emit volatile organic compounds from Source ID 165 shall be less than 2.7 tons per year.

II. TESTING REQUIREMENTS.

No additional testing requirements exist except as provided in other sections of this permit including Section B (Title V General Requirements).

III. MONITORING REQUIREMENTS.

No additional monitoring requirements exist except as provided in other sections of this permit including Section B (Title V General Requirements).

IV. RECORDKEEPING REQUIREMENTS.**# 002 [25 Pa. Code §127.441]****Operating permit terms and conditions.**

[Additional authority for this permit condition is derived from 25 Pa. Code Sections 129.91-129.95 and 129.115(f).]

The permittee shall maintain records of calculations or emission test reports to verify compliance with the volatile organic compound emission rate limitations for Source ID 165. These records shall be retained for a minimum of five (5) years and made available to the Department upon request.

V. REPORTING REQUIREMENTS.**# 003 [25 Pa. Code §127.441]****Operating permit terms and conditions.**

The permittee shall report the records of calculations to verify compliance with the volatile organic compound (VOC) emission rates for Source ID. 165 on an annual basis. Annual reports shall be submitted to the Department by March 1 for the preceding period January to December.

VI. WORK PRACTICE REQUIREMENTS.**# 004 [25 Pa. Code §127.441]****Operating permit terms and conditions.**

[Additional authority for this permit condition is derived from 25 Pa. Code Section 129.112(c).]

**SECTION D. Source Level Requirements**

The permittee shall install, maintain and operate the sources identified under Source ID 165 in accordance with the manufacturer's specifications and with good operating practices.

VII. ADDITIONAL REQUIREMENTS.

005 [25 Pa. Code §127.441]

Operating permit terms and conditions.

Source ID. 165 consists of glycol tanks used in plant chilling and condenser systems. The tanks of Source ID. 165 are identified as follows:

TA-400 TA-420 TA-461 TA-462 TA-481 TA-482 TA-990 TA-485 TA-486

***** Permit Shield in Effect. *****

**SECTION D. Source Level Requirements**

Source ID: 175

Source Name: RECIPROCATING INTERNAL COMBUSTION ENGINES

Source Capacity/Throughput:

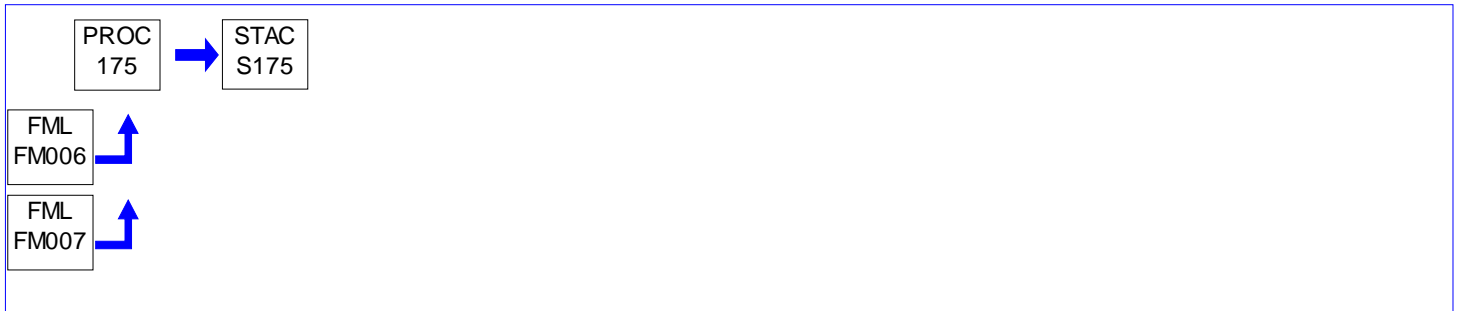
**I. RESTRICTIONS.****Emission Restriction(s).****# 001 [25 Pa. Code §123.13]****Processes**

No person may permit the emission from any reciprocating internal combustion engine incorporated into Source ID 175 in a manner such that the emission of particulate matter into the outdoor atmosphere is in excess of 0.04 grains per dry standard cubic foot.

002 [25 Pa. Code §123.21]**General**

No person may permit the emission from any reciprocating internal combustion engine incorporated into Source ID 175 in such a manner that the concentration of sulfur oxides, expressed as SO₂, in the exhaust to the outdoor atmosphere is in excess of 500 parts per million, by volume, dry basis.

003 [25 Pa. Code §127.441]**Operating permit terms and conditions.**

(a) The nitrogen oxides (NO_x) emissions from the Cummins model KTTA19-G2 (DG-109) emergency generator of Source ID 175 shall not exceed 11.39 grams per brake horsepower-hour.

(b) The VOC emissions from the Cummins model KTTA19-G2 (DG-109) emergency generator of Source ID 175 shall not exceed 0.36 grams per brake horsepower-hour.

004 [25 Pa. Code §127.441]**Operating permit terms and conditions.**

[Additional authority for this permit condition is derived from 25 Pa. Code Sections 127.1 and 127.12. Compliance with this streamlined permit condition assures compliance with 25 Pa. Code Sections 123.13 and 123.21.]

The Kohler #900ROZD (DG-263) emergency generator of Source ID 175 shall not exceed the following emission limits:

- (a) nitrogen oxides (NO_x, expressed as NO₂); 20,400 Grams per hour, 9.6 tons in any 12 consecutive month period;
- (b) carbon monoxide; 2,400 Grams per hour, 1.1 tons in any 12 consecutive month period;
- (c) volatile organic compounds; 432 Grams per hour, 0.2 ton in any 12 consecutive month period;
- (d) Total particulate matter; 670 Grams per hour, 0.3 ton in any 12 consecutive month period;
- (e) PM₁₀; 670 Grams per hour, 0.3 ton in any 12 consecutive month period;
- (f) sulfur dioxide; 1.2 tons in any 12 consecutive month period.

005 [25 Pa. Code §127.441]**Operating permit terms and conditions.**

[Additional authority for this permit condition is derived from 25 Pa. Code Sections 127.1 and 127.12. Compliance with this streamlined permit condition assures compliance with 25 Pa. Code Section 123.13.]

The Cummins model C150D6D (DG-261), 324 bhp, emergency generator of Source ID 175 shall not exceed the following emission limits:

**SECTION D. Source Level Requirements**

- (a) nitrogen oxides (NO_x, expressed as NO₂): 6.9 grams per brake horsepower-hour;
- (b) carbon monoxide; 2.0 grams per brake horsepower-hour;
- (c) Total Hydrocarbons: 1.0 grams per brake horsepower-hour;
- (d) Total particulate matter: 0.4 grams per brake horsepower-hour.

006 [40 CFR Part 60 Standards of Performance for New Stationary Sources §40 CFR 60.4205]
Subpart IIII - Standards of Performance for Stationary Compression Ignition Internal Combustion Engines
What emission standards must I meet for emergency engines if I am an owner or operator of a stationary CI internal co

(a) The air contaminant emissions from the Kohler model 80REOZJF (DG-301), 133 horsepower, emergency generator engine shall not exceed the following limitations:

- (i) NO_x+NMHCs - 4.0 g/kW-hr;
- (ii) CO - 5.0 g/kW-hr;
- (iii) PM - 0.30 g/kW-hr.

(b) The air contaminant emissions from the Cummins model C150D6D (DG-261), 324 bhp, emergency generator engine shall not exceed the following limitations:

- (i) NO_x+NMHCs - 4.0 g/kW-hr;
- (ii) CO - 3.5 g/kW-hr;
- (iii) PM - 0.20 g/kW-hr.

Additionally, pursuant to 40 CFR 60.4206, the engines shall comply with these emission standards for the life of the engines.

007 [40 CFR Part 60 Standards of Performance for New Stationary Sources §40 CFR 60.4233]
Subpart JJJJ - Standards of Performance for Stationary Spark Ignition Internal Combustion Engines
What emission standards must I meet if I am an owner or operator of a stationary SI internal combustion engine?

The air contaminant emissions from the Generac model QT060 (PG-119), 80 horsepower, emergency generator shall not exceed the following limitations:

- (a) Nitrogen oxides plus hydrocarbons (NO_x + HC) - 10 grams per brake horsepower-hour.
- (b) Carbon monoxide - 387 grams per brake horsepower-hour.

Fuel Restriction(s).

008 [25 Pa. Code §127.441]
Operating permit terms and conditions.

[Compliance with this condition ensures compliance with 25 Pa. Code Section 123.22 and, with respect to the operation of the 133 hp Kohler model 80REOZJF and the 324 bhp Cummins model C150D6D emergency generators, 40 CFR 60.4207(b).]

All diesel-fired engines under Source ID 175 shall be fired only on #2 fuel oil with a maximum sulfur content of 0.0015% by weight and to which no reclaimed or waste oil or other waste materials have been added.

009 [25 Pa. Code §127.441]
Operating permit terms and conditions.

The engines referenced by the permittee as GN-124 and PG-119 shall be fired only on propane.

Operation Hours Restriction(s).

010 [25 Pa. Code §127.441]
Operating permit terms and conditions.

[Compliance with this condition ensures compliance with 40 CFR 60.4243(d) and 40 CFR 60.4211(f).]

The Generac model QT060 (PG-119), 80 horsepower, emergency generator, the Kohler model 80REOZJF (DG-301), 133 horsepower, emergency generator, and the Cummins model C150D6D (DG-261), 324 bhp emergency generator engines

**SECTION D. Source Level Requirements**

may each be operated for the purpose of maintenance checks and readiness testing, provided that the tests are recommended by Federal, State or local government, the manufacturer, the vendor, or the insurance company associated with the emergency generator. Maintenance checks and readiness testing of such units is limited to 100 hours per year. The permittee may petition the Department for approval of additional hours to be used for maintenance checks and readiness testing, but a petition is not required if the permittee maintains records indicating that Federal, State, or local standards require maintenance and testing of these emergency generators beyond 100 hours per year. These emergency generators may operate up to 50 hours per year in non-emergency situations, but those 50 hours are counted towards the 100 hours per year provided for maintenance and testing. The 50 hours per year for non-emergency situations cannot be used for peak shaving or to generate income for a facility to supply power to an electric grid or otherwise supply power as part of a financial arrangement with another entity. Any operation of these emergency generators, other than emergency operation, maintenance and testing, and operation in non-emergency situations for 50 hours per year, as permitted in this condition, is prohibited.

011 [25 Pa. Code §127.441]**Operating permit terms and conditions.**

[Additional authority for this permit condition is derived from 25 Pa. Code Sections 129.96 - 129.100 and 129.111 - 129.115.]

Pursuant to 25 Pa. Code Sections 129.97(c)(8) and 129.112(c)(10), the permittee shall operate each source incorporated into Source ID 175 (with the exception of the Kohler model #900ROZD generator, DG-263) less than 500 hours in any 12 consecutive month period.

012 [25 Pa. Code §127.441]**Operating permit terms and conditions.**

[Additional authority for this permit condition is derived from 25 Pa. Code Sections 129.91 - 129.95. Compliance with this streamlined condition ensures compliance with 25 Pa. Code Sections 129.111-129.115.]

The permittee shall not operate the Kohler model #900ROZD generator (DG-263) of Source ID 175 more than 427 hours in any 12 consecutive month period.

II. TESTING REQUIREMENTS.

No additional testing requirements exist except as provided in other sections of this permit including Section B (Title V General Requirements).

III. MONITORING REQUIREMENTS.**# 013 [25 Pa. Code §127.441]****Operating permit terms and conditions.**

Each engine of Source ID 175 shall be equipped with non-resettable hour meter to monitor each engine's runtime on a continuous basis in order to verify compliance with the hours of operation restrictions incorporated herein.

IV. RECORDKEEPING REQUIREMENTS.**# 014 [25 Pa. Code §127.441]****Operating permit terms and conditions.**

(a) The permittee shall maintain records of the following information:

- (1) the number of hours each source of Source ID 175 is operated per month, including the 12-month total calculation to verify compliance with the 12 consecutive month hours of operation restrictions incorporated herein.
- (2) calculations or emission test reports used to verify compliance with the particulate matter and sulfur oxides emission limitations for each process of Source ID 175
- (3) test reports or fuel analysis reports of the sulfur % of #2 fuel oil used for each engine of Source ID 175
- (4) calculations or emission test reports used to verify compliance with the hourly NO_x, CO, VOC, and total particulate matter (including PM-10) emissions limitations for the Kohler #900ROZD (DG-263) emergency generator of Source ID 175
- (5) calculations or emission test reports used to verify compliance with the NO_x and VOC emissions limitations for the Cummins model KTTA19-G2 (DG-109) emergency generator of Source ID 175

**SECTION D. Source Level Requirements**

(6) NO_x, CO, SO_x, VOC and total particulate matter (including PM-10) emissions calculations or emission test reports to verify compliance with the annual emission limitations for the Kohler model #900ROZD (DG-263) emergency generator of Source ID 175

(b) These records shall be made available to the Department upon request and shall remain on file for five (5) years.

015 [40 CFR Part 60 Standards of Performance for New Stationary Sources §40 CFR 60.4214]

Subpart III - Standards of Performance for Stationary Compression Ignition Internal Combustion Engines

What are my notification, reporting, and recordkeeping requirements if I am an owner or operator of a stationary CI internal combustion engine?

The permittee shall keep records pertaining to the Kohler model 80REOZJF (DG-301), 133 horsepower, emergency generator and the Cummins model C150D6D (DG-261), 324 bhp, emergency generator as specified in 40 CFR § 60.4214.

016 [40 CFR Part 60 Standards of Performance for New Stationary Sources §40 CFR 60.4245]

Subpart JJJJ - Standards of Performance for Stationary Spark Ignition Internal Combustion Engines

What are my notification, reporting, and recordkeeping requirements if I am an owner or operator of a stationary SI internal combustion engine?

The permittee shall keep records pertaining to the Generac model QT060 (PG-119), 80 horsepower, emergency generator as specified in 40 CFR § 60.4245.

V. REPORTING REQUIREMENTS.

017 [25 Pa. Code §127.441]

Operating permit terms and conditions.

(a) The permittee shall provide annual reports with the monthly hours of operation, including the 12-month total calculation to verify compliance with the 12 consecutive month hours of operation restrictions incorporated herein for each engine incorporated in Source 175 on an annual basis.

(b) Annual reports shall be provided to the Department by March 1 for the previous calendar year.

018 [25 Pa. Code §127.441]

Operating permit terms and conditions.

(a) The permittee shall submit to the Department on an annual basis records of the monthly emissions of NO_x, SO_x, CO, VOC, particulate, and particulate (PM-10) including 12 consecutive month total emissions of these pollutants as well as the supporting emission calculations to verify compliance with the annual emissions limitations for the Kohler model #900ROZD (referred to as DG-263) emergency generator of Source ID 175

(b) Annual reports shall be submitted by March 1 for the preceding operating period from January to December of the previous calendar year.

019 [40 CFR Part 60 Standards of Performance for New Stationary Sources §40 CFR 60.4214]

Subpart III - Standards of Performance for Stationary Compression Ignition Internal Combustion Engines

What are my notification, reporting, and recordkeeping requirements if I am an owner or operator of a stationary CI internal combustion engine?

The permittee shall submit notifications and reports pertaining to the Kohler model 80REOZJF (DG-301), 133 horsepower, emergency generator and the Cummins model C150D6D (DG-261), 324 bhp, emergency generator as specified in 40 CFR § 60.4214.

020 [40 CFR Part 60 Standards of Performance for New Stationary Sources §40 CFR 60.4245]

Subpart JJJJ - Standards of Performance for Stationary Spark Ignition Internal Combustion Engines

What are my notification, reporting, and recordkeeping requirements if I am an owner or operator of a stationary SI internal combustion engine?

The permittee shall submit notifications and reports pertaining to the Generac model QT060 (PG-119), 80 horsepower, emergency generator as specified in 40 CFR § 60.4245.

**SECTION D. Source Level Requirements****VI. WORK PRACTICE REQUIREMENTS.****# 021 [40 CFR Part 60 Standards of Performance for New Stationary Sources §40 CFR 60.4211]****Subpart III - Standards of Performance for Stationary Compression Ignition Internal Combustion Engines****What are my compliance requirements if I am an owner or operator of a stationary CI internal combustion engine?**

With respect to the Kohler model 80REOZJF (DG-301), 133 horsepower, emergency generator engine and the Cummins model C150D6D (DG-261), 324 bhp, emergency generator, the permittee shall operate and maintain the engine according to the manufacturer's emission-related written instructions; change only those emission-related settings that are permitted by the manufacturer; and meet the requirements of 40 CFR parts 89, 94 and/or 1068, as applicable.

022 [40 CFR Part 60 Standards of Performance for New Stationary Sources §40 CFR 60.4243]**Subpart JJJJ - Standards of Performance for Stationary Spark Ignition Internal Combustion Engines****What are my compliance requirements if I am an owner or operator of a stationary SI internal combustion engine?**

With respect to the operation of the Generac model QT060 (PG-119), 80 horsepower, emergency generator, the permittee shall keep a maintenance plan and records of conducted maintenance and must, to the extent practicable, maintain and operate the engine in a manner consistent with good air pollution control practice for minimizing emissions.

VII. ADDITIONAL REQUIREMENTS.**# 023 [25 Pa. Code §127.441]****Operating permit terms and conditions.**

Source ID 175 is a group of ten (10) emergency generators and two (2) fire pumps, described as follows:

- (a) One 325 horsepower Cummins model NT-38011F emergency fire pump, referenced as PU-304 W (west);
- (b) One (1) 45.6 horsepower Kohler model 30RZG, propane-fired, emergency generator, referenced as GN-124;
- (c) One (1) Kohler model 750ROZD4, 1120 horsepower emergency generator located adjacent to Building 317, referenced as DG-302C;
- (d) One (1) Cummins/Onan model 500DFFB, 685 horsepower emergency generator located adjacent to Building 107, referenced as DG-7018;
- (e) One (1) Detroit-Diesel Allison, Inc. model DDFP-LGFA8418, 305 horsepower emergency fire water pump located in Building 304, referenced as PU-304 E (east);
- (f) One (1) Cummins model KTTA19-G2, 750 horsepower emergency generator, referenced as DG-109;
- (g) One (1) Kohler model #900ROZD, 1340 horsepower emergency generator located in the Power Plant, referenced as DG-263;
- (h) One (1) Kohler model 150REOZJB, 251 horsepower emergency generator located in the Building 112 computer and telecommunication rooms, referenced as DG-112;
- (i) One (1) Kohler model 250REOZV, 335.25 horsepower emergency generator located outside of Building 218 as a backup to the potable water power supply system, referenced as DG-218;
- (j) One (1) Generac model QT060, 80 horsepower, propane-fired, emergency generator, referenced as PG-119, located adjacent to building B-119;
- (k) one (1) Kohler model 80REOZJF, 133 horsepower, diesel-fired, emergency generator, referenced as DG-301, located adjacent to building B-301. This generator was originally constructed under RFD #6019, approved December 1, 2016.
- (l) one (1) Cummins model C150D6D, 324 bhp, diesel-fired emergency generator, referenced as DG-261, located adjacent to building B-261. This generator was originally constructed under general plan approval/operating permit AG9-49-00001A, issued July 15, 2020.

024 [40 CFR Part 60 Standards of Performance for New Stationary Sources §40 CFR 60.4200]**Subpart III - Standards of Performance for Stationary Compression Ignition Internal Combustion Engines****Am I subject to this subpart?**

The Kohler model 80REOZJF (DG-301), 133 horsepower, emergency generator and the Cummins model C150D6D (DG-261), 324 bhp, emergency generator are subject to the requirements of the Standards of Performance for Stationary Compression Ignition Internal combustion Engines pursuant to 40 CFR Part 60 Subpart III, Section 60.4200 through 60.4219. The permittee shall comply with all applicable requirements of 40 CFR Part 60 Subpart III, Section 60.4200 through 60.4219.

025 [40 CFR Part 60 Standards of Performance for New Stationary Sources §40 CFR 60.4230]**Subpart JJJJ - Standards of Performance for Stationary Spark Ignition Internal Combustion Engines****Am I subject to this subpart?**

**SECTION D. Source Level Requirements**

The Generac model QT060 (PG-119), 80 horsepower, emergency generator is subject to 40 CFR Part 60 Subpart JJJJ - Standards of Performance for Stationary Spark Ignition Internal Combustion Engines. The permittee shall comply with all applicable requirements specified in 40 CFR Sections 60.4230 through 60.4248.

026 [40 CFR Part 63 NESHAPS for Source Categories §40 CFR 63.6585]

Subpart ZZZZ - National Emissions Standards for Hazardous Air Pollutants for Stationary Reciprocating Internal Combustion Engines

Am I subject to this subpart?

Source ID 175 is subject to the requirements of the National Emissions Standards for Hazardous Air Pollutants for Stationary Reciprocating Internal Combustion Engines pursuant to 40 CFR Part 63 Subpart ZZZZ Section 63.6580 through 63.6675. The permittee shall comply with all applicable requirements of 40 CFR Part 63 Subpart ZZZZ Section 63.6580 through 63.6675.

***** Permit Shield in Effect. *****

**SECTION D. Source Level Requirements**

Source ID: 180

Source Name: LOADING OPERATIONS

Source Capacity/Throughput:

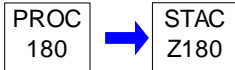
**I. RESTRICTIONS.****Emission Restriction(s).****# 001 [25 Pa. Code §127.441]****Operating permit terms and conditions.**

[Compliance with this streamlined permit condition ensures compliance with 25 Pa. Code Sections 129.97(c)(2) and 129.112(c)(2).]

- (a) The volatile organic compound (VOC) emissions from the B-316 tank wagon loading station of Source ID 180 shall not exceed 1.0 tons in any 12 consecutive month period.
- (b) The volatile organic compound (VOC) emissions from the South Tank Farm tank wagon/railcar loading/unloading operation of Source ID 180 shall not exceed 1.0 tons in any 12 consecutive month period.
- (c) The volatile organic compound (VOC) emissions from all tank truck loading/unloading stations associated with Source ID 180 shall be less than 2.7 tons per year.

002 [25 Pa. Code §127.441]**Operating permit terms and conditions.**

- (a) Emissions of any single hazardous air pollutant (HAP) from the B-316 tank wagon loading station of Source ID. 180 shall not exceed 1.0 tons in any 12 consecutive month period. The combined HAP emissions from the B-316 tank wagon loading station of Source ID. 180 shall not exceed 2.5 tons in any 12 consecutive month period.
- (b) Emissions of any single hazardous air pollutant (HAP) from the South Tank Farm tank wagon/railcar loading/unloading operation of Source ID. 180 shall not exceed 1.0 tons in any 12 consecutive month period. The combined HAP emissions from the South Tank Farm tank wagon/railcar loading/unloading operation of Source ID. 180 shall not exceed 2.5 tons in any 12 consecutive month period.

Throughput Restriction(s).**# 003 [25 Pa. Code §127.441]****Operating permit terms and conditions.**

Pursuant to the best available technology provisions of 25 Pa. Code Sections 127.1 and 127.12, all tank trucks filled at the loading/unloading stations associated with Source ID 180 shall be filled subsurfacely.

II. TESTING REQUIREMENTS.

No additional testing requirements exist except as provided in other sections of this permit including Section B (Title V General Requirements).

III. MONITORING REQUIREMENTS.

No additional monitoring requirements exist except as provided in other sections of this permit including Section B (Title V General Requirements).

IV. RECORDKEEPING REQUIREMENTS.**# 004 [25 Pa. Code §127.441]****Operating permit terms and conditions.**

Pursuant to 25 Pa. Code Sections 129.100(d) and 129.115(f), the permittee shall maintain records that ensure all sources under Source ID 180 are being maintained and operated in accordance with the manufacturer's specifications and with good operating practices. These records shall be maintained for at least five years and made available to the Department

**SECTION D. Source Level Requirements**

upon request.

005 [25 Pa. Code §127.441]**Operating permit terms and conditions.**

[Additional authority for this permit condition with respect to VOC emissions is derived from 25 Pa. Code Sections 129.100(d) and 129.115(f).]

(a) The permittee shall keep records of the following operating parameters for Source ID 180:

- (1) Calculations or emission test reports to verify compliance with the annual VOC and HAP emissions limitations for the B-316 tank wagon loading station;
- (2) Calculations or emission test reports to verify compliance with the annual VOC and HAP emissions limitations for the South Tank Farm tank wagon/railcar loading/unloading operation;

(b) These records shall remain on file for a minimum of five (5) years and shall be made available to the Department upon request.

V. REPORTING REQUIREMENTS.**# 006 [25 Pa. Code §127.441]****Operating permit terms and conditions.**

The permittee shall report to the Department records of calculations used to verify the annual emission limitations for Source ID 180 on an annual basis. Annual reports shall be submitted by March 1 for the preceding period January to December.

VI. WORK PRACTICE REQUIREMENTS.**# 007 [25 Pa. Code §127.441]****Operating permit terms and conditions.**

[Additional authority for this permit condition is derived from 25 Pa. Code Section 129.112(c).]

The permittee shall install, maintain and operate the sources identified under Source ID 180 in accordance with the manufacturer's specifications and with good operating practices.

VII. ADDITIONAL REQUIREMENTS.**# 008 [25 Pa. Code §127.441]****Operating permit terms and conditions.**

Source ID 180 consists of the following:

- (a) a B-316 tank wagon loading station used to fill tankwagons with waste solvents from tanks in the Factory 6/7 Tank Farm (Source ID 155) or from processing equipment included in Source ID 140.
- (b) a tank wagon/railcar loading/unloading operation used to load waste solvents into tank wagons and railcars, located in the facility's South Tank Farm (included in Source ID 155).

***** Permit Shield in Effect. *****

**SECTION D. Source Level Requirements**

Source ID: 250

Source Name: DRUM HANDLING AND SAMPLING AREA

Source Capacity/Throughput:

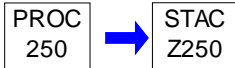
**I. RESTRICTIONS.****Emission Restriction(s).****# 001 [25 Pa. Code §127.441]****Operating permit terms and conditions.**

[Additional authority for this permit condition is derived from 25 Pa. Code Sections 129.91 - 129.95. Compliance with this streamlined condition ensures compliance with 25 Pa. Code Sections 129.111-129.115.]

The potential to emit volatile organic compounds from the drum handling operations of Source ID 250 shall not exceed 3 pounds per hour or 15 pounds per day.

002 [25 Pa. Code §127.441]**Operating permit terms and conditions.**

[Compliance with this permit condition ensures compliance with 25 Pa. Code Sections 129.97(c)(2) and 129.112(c)(2).]

The potential to emit VOCs from the drum handling operations of Source ID 250 shall not exceed 1.2 tons in any 12 consecutive month period.

II. TESTING REQUIREMENTS.

No additional testing requirements exist except as provided in other sections of this permit including Section B (Title V General Requirements).

III. MONITORING REQUIREMENTS.

No additional monitoring requirements exist except as provided in other sections of this permit including Section B (Title V General Requirements).

IV. RECORDKEEPING REQUIREMENTS.**# 003 [25 Pa. Code §127.441]****Operating permit terms and conditions.**

Pursuant to 25 Pa. Code Sections 129.100(d) and 129.115(f), the permittee shall maintain records that ensure all sources under Source ID 250 are being maintained and operated in accordance with the manufacturer's specifications and with good operating practices. These records shall be maintained for at least five years and made available to the Department upon request.

004 [25 Pa. Code §127.441]**Operating permit terms and conditions.**

[Additional authority for this permit condition is derived from 25 Pa. Code Sections 129.91 - 129.95, 129.100(d) and 129.115(f).]

The permittee shall maintain records of calculations or emission test reports used to verify compliance with the volatile organic compound (VOC) emission rate limitations for the drum handling operations of Source ID 250.

These records shall be retained for a minimum of five (5) years and shall be made available to the Department upon request.

**SECTION D. Source Level Requirements****V. REPORTING REQUIREMENTS.****# 005 [25 Pa. Code §127.441]****Operating permit terms and conditions.**

The permittee shall report the records of calculations used to verify compliance with the volatile organic compound (VOC) emission rate limitations for the drum handling operations of Source ID 250 on an annual basis.

The annual reports shall be submitted by March 1 for the preceding period January to December of the following calendar year.

VI. WORK PRACTICE REQUIREMENTS.**# 006 [25 Pa. Code §127.441]****Operating permit terms and conditions.**

[Additional authority for this permit condition is derived from 25 Pa. Code Section 129.112(c).]

The permittee shall install, maintain and operate the sources identified under Source ID 250 in accordance with the manufacturer's specifications and with good operating practices.

VII. ADDITIONAL REQUIREMENTS.**# 007 [25 Pa. Code §127.441]****Operating permit terms and conditions.**

Source ID 250 consists of drum handling operations consisting of drum filling operations (in-plant transfer of materials into drums and/or material holding in-process) and a drum washing station (clean-out of empty raw material drums prior to disposal and optional use of scrubber for emissions control).

***** Permit Shield in Effect. *****

**SECTION D. Source Level Requirements**

Source ID: 260

Source Name: ONSITE LABORATORIES

Source Capacity/Throughput:

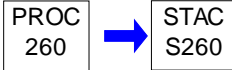
**I. RESTRICTIONS.****Emission Restriction(s).****# 001 [25 Pa. Code §127.441]****Operating permit terms and conditions.**

[Additional authority for this permit condition is derived from 25 Pa. Code Sections 129.91-129.95, 129.96–129.100 and 129.111–129.115.]

(a) Pursuant to 25 Pa. Code Section 129.91, the potential to emit volatile organic compounds from Source ID 260 shall never exceed 3 pounds per hour or 15 pounds per day in any 12 consecutive month period. Should any of these limitations ever be exceeded, a detailed RACT analysis which meets the criteria specified in Section 129.92 of 25 Pa. Code Chapter 129 must be submitted to the Department for Source ID 260.

(b) Pursuant to 25 Pa. Code Sections 129.97(c)(2) and 129.112(c)(2), the potential to emit volatile organic compounds from Source ID 260 shall be less than 2.7 tons per year.

II. TESTING REQUIREMENTS.

No additional testing requirements exist except as provided in other sections of this permit including Section B (Title V General Requirements).

III. MONITORING REQUIREMENTS.

No additional monitoring requirements exist except as provided in other sections of this permit including Section B (Title V General Requirements).

IV. RECORDKEEPING REQUIREMENTS.**# 002 [25 Pa. Code §127.441]****Operating permit terms and conditions.**

[Additional authority for this permit condition is derived from 25 Pa. Code Sections 129.91-129.95, 129.100(d) and 129.115(f).]

The permittee shall maintain records of calculations or emission test reports to verify compliance with the volatile organic compound emission rate limitations for Source ID 260. These records shall be retained for a minimum of five (5) years and made available to the Department upon request.

V. REPORTING REQUIREMENTS.**# 003 [25 Pa. Code §127.441]****Operating permit terms and conditions.**

The permittee shall report the records of calculations to verify the volatile organic compound (VOC) emission rates for Source ID 260 on an annual basis. Annual reports shall be submitted by no later than March 1 of the following calendar year.

VI. WORK PRACTICE REQUIREMENTS.**# 004 [25 Pa. Code §127.441]****Operating permit terms and conditions.**

[Additional authority for this permit condition is derived from 25 Pa. Code Section 129.112(c).]

**SECTION D. Source Level Requirements**

The permittee shall install, maintain and operate the sources identified under Source ID 260 in accordance with the manufacturer's specifications and with good operating practices.

VII. ADDITIONAL REQUIREMENTS.

005 [25 Pa. Code §127.441]

Operating permit terms and conditions.

Source ID. 260 includes laboratory fume hoods associated with onsite laboratories used in product and raw material quality control testing, bench scale research, and process development.

***** Permit Shield in Effect. *****



SECTION E. Source Group Restrictions.



SECTION F. Alternative Operation Requirements.

No Alternative Operations exist for this Title V facility.

**SECTION G. Emission Restriction Summary.**

No emission restrictions listed in this section of the permit.

**SECTION H. Miscellaneous.**

As per a request from the permittee and information submitted as part of the Title V permit application for the Riverside Boro. Plant, the following requirements are not applicable to the sources at the facility as specified:

- (1) 25 Pa. Code Section 129.63 (for the facility)
- (2) 40 CFR Part 60 Subpart Ce (for the facility)
- (3) 40 CFR Part 60 Subpart Kb for tank TA-870 of Source ID 131. Please also refer to the letter dated March 13, 2001 from EPA to the Department for information concerning this determination.
- (4) 40 CFR Part 60 Subpart O (for the facility).



***** End of Report *****
